

The Vertikal Guide

for buyers and users of lifting equipment
para compradores y usuarios de equipos de elevación



Cranes
Aerial lifts
Telehandlers

Grúas
Manipuladores
Telescópicos
Plataformas



**YOUR STANDARDS
ARE RAISED EVERY DAY**

**GET A HEAD START
WITH THE JLG PS SERIES**

**JLG @ CONEXPO
GOLD LOT 1037**

ALL THE POWER AND LIFT YOU NEED. The JLG® PS Series of telehandlers optimises productivity and reliability on today's toughest jobsites. With four models available, PS telehandlers adapt to a variety of applications – delivering capacities of up to 4.0 tons and lift heights of up to 17.3m, while accepting a multitude of options and attachments to customise performance. Take your productivity to the next level, with heavy-duty JLG PS telehandlers and the JLG customer service and support team. JLG. Helping you reach your potential.

www.jlg.com

JLG International | Polaris Avenue 63 | 2132 JH | Hoofddorp | The Netherlands

JLG
reachingout.™



Editors:

Mark Darwin
Ed Darwin
Rüdiger Kopf
Alexander Ochs
Macarena Garcia

Advertising & Sales:

Karlheinz Kopp
Pam Penny
Clare Engelke

Production:

Nicole Engesser
Leigh W. Sparrow

Publisher:

Leigh W. Sparrow

The Vertikal Press Ltd:

PO box 6998 Brackley
NN13 5WY, UK
Tel: +44(0)8448 155900
Fax: +44(0)1295 768223
E-mail: info@vertikal.net

Vertikal Verlag:

Sundgaualle 15, D-79114,
Freiburg, Germany
Tel: +49 761 8978660
Fax: +49 761 8866814
E-mail: info@vertikal.net

Design & Artwork by:

bp design
Tel: +44 (0) 208 245 5715
E-mail: studio@bpdesign.info

Good times are on the way?



Three years ago the introduction to Conexpo 2011 was entitled 'A positive Trend' and looking back we made a fairly accurate prediction of the years that followed. Almost six years after the global recession struck things are looking brighter, but different.

Equipment users need to look even more carefully at the products they source, whether purchasing or renting. When it comes to cranes, aerial lifts or telehandlers technology developments are arriving thick and fast offering benefits in terms of performance and efficiency, not to mention regulation compliance.

Equipment prices have also been rising and are not likely to change any time soon. Buyers can however benefit significantly from using equipment that is less costly to operate, easier to transport and set up, and safer to use. As well as this mobile information systems are finally coming of age providing substantial opportunities for smart operators.

Do take advantage of having all the major manufacturers and their most senior managers together at the show. Learn about their new products and technology, as well as developing relationships that will serve you well in the year ahead. And don't overlook the opportunity to meet fellow exhibition visitors, who will have travelled from all over the world and who share your interests.

This guide - with its large maps, exhibitor listings and guided tours - will prove invaluable. And finally this is Las Vegas so the back third of the guide is dedicated to the city and all the fun that it offers.

Have a great week.

Leigh W Sparrow

¿Están los buenos tiempos en camino?



Hace tres años la introducción de Conexpo 2011 se titulaba «Una tendencia positiva», y mirando hacia atrás vemos que hicimos una predicción bastante exacta de los años que siguieron. Casi seis años después de la recesión global, las cosas se ven más brillantes, pero diferente.

Los usuarios de equipos tienen que mirar con más cuidado en los productos que buscan, compran o alquilan. Cuando se trata de grúas, plataformas elevadoras o manipuladores telescópicos los desarrollos tecnológicos están llegando en masa y son rápidos los beneficios que ofrece en términos de rendimiento y eficacia, sin olvidar el cumplimiento de la regulación.

Los precios de los equipos también han ido en aumento y no es probable que cambie en el corto plazo. Sin embargo los compradores pueden beneficiarse significativamente de usar equipos menos costosos de operar, más fáciles de transportar y de instalar, y más seguros de usar. Además de estos sistemas de información móviles finalmente están acercando a la madurez, por lo que proporcionan importantes oportunidades para los operadores inteligentes.

Aprovechese de tener todos los principales fabricantes y sus más altos directivos juntos en un espacio pequeño. Aprenda acerca de sus nuevos productos y tecnologías, así como el desarrollo de relaciones que le servirán bien el próximo año. Y no pase por alto la oportunidad de conocer a los visitantes de la feria, quienes han viajado de todas partes del mundo y que comparten sus intereses.

Esta guía - con sus grandes mapas, listados de expositores y visitas guiadas - será de gran valor. Y finalmente, esto es Las Vegas, por lo que la tercera parte de atrás de la guía está dedicada a la ciudad y toda la diversión que ofrece.

Que tengan una gran semana.

Leigh W Sparrow

Vertikal
.net

cranes & access **Vertical days**

Kran & Bühne

IABS
TAG DER ARBEITSBUHNESECHENIT

facebook

twitter

HR17 Hybrid 4x4

nifty
Innovations

The **HR17 Hybrid 4x4** is one of a new generation of environmentally conscious work platforms from **Niftylift**.

- Efficient, intelligent **Hybrid** power
- Zero emission electric-only mode
- Compact & low weight chassis
- Class leading working envelope
- SiOPS® & ToughCage as standard

The **HR17 Hybrid 4x4** embodies the very best of Niftylift's design philosophy, combining advanced and patented **Hybrid** power-source technology with capable 4-wheel-drive.

It delivers class leading reach performance from a compact, super-low-weight and manoeuvrable chassis.

With **SiOPS®** and **ToughCage** as standard, operators can work with confidence that their safety is paramount.

The **HR17 Hybrid 4x4** is the ultimate combination of performance, economy, and most importantly safety.



USE SMART PHONE Q R CODE READER

To learn more about the Nifty **HR17 Hybrid 4x4**, please visit our website.

To arrange a demo, please call us now on:

+44 (0)1908 223456



VISIT US AT BOOTH
4188
SILVER LOT 1



niftylift.com

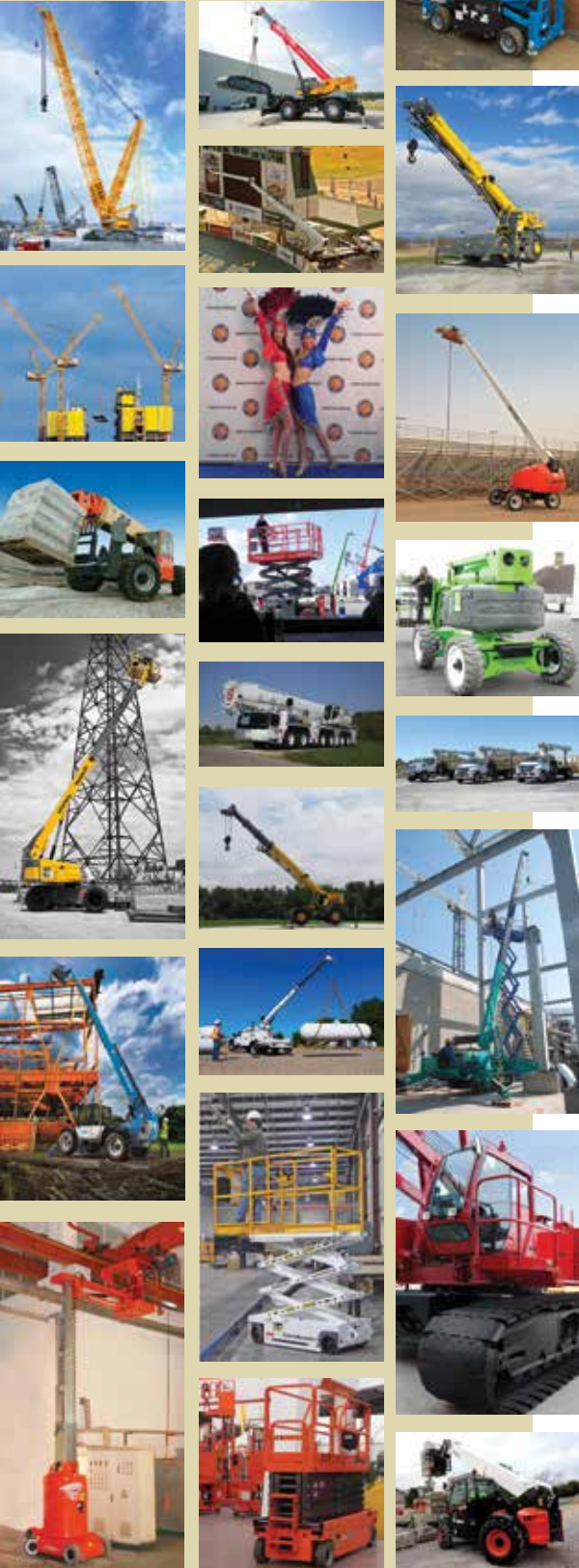

3	Introduction • Introducción
5	Contents • Contenido
6	Exhibition plans • Planos de exhibición
15	Exhibitor lists • Lista de expositors
18	All Terrain & Truck cranes • Grúas todo terreno
21	Rough Terrain cranes • Grúas para terrenos accidentados
22	Crawler cranes • Grúas de celosia
25	Boom truck & loader cranes • Grúas hidráulicas sobre camion
27	Tower cranes • Grúas torre
29	Spider cranes • Grúa Araña
30	Overhead power line risks •
33	Self-propelled booms • Plataformas autopropulsadas
37	Scissor lifts • Plataformas de tijera
39	Tracked and trailer lifts • Elevadores de araña y remolcables
41	Truck mounted lifts • Plataformas sobre camión
43	Mastclimbers • Plataformas de másti
45	Telehandlers • Manipuladores telescópicos
49	Remote controls • Control remoto
51	Components • Componentes
52	Getting around Las Vegas • Moverse por Las Vegas
54	Las Vegas Monorail Map • Mapa Las Vegas
55	Sights of Las Vegas • Puntos de interés de Las Vegas
56	Restaurants • Restaurantes
58	Its not Gambling • Se trata de jugar
59	Las Vegas Shows • Espectáculos
60	Trips further afield • Mas Alla
61	Time for Golf • Campos de golf
62	Marketplace



CONEXPO-CON/AGG overview map

MARCH 4 - 8, 2014 • 9:00 AM - 5:00 PM TUESDAY - FRIDAY • 9:00 AM - 3:00 PM SATURDAY

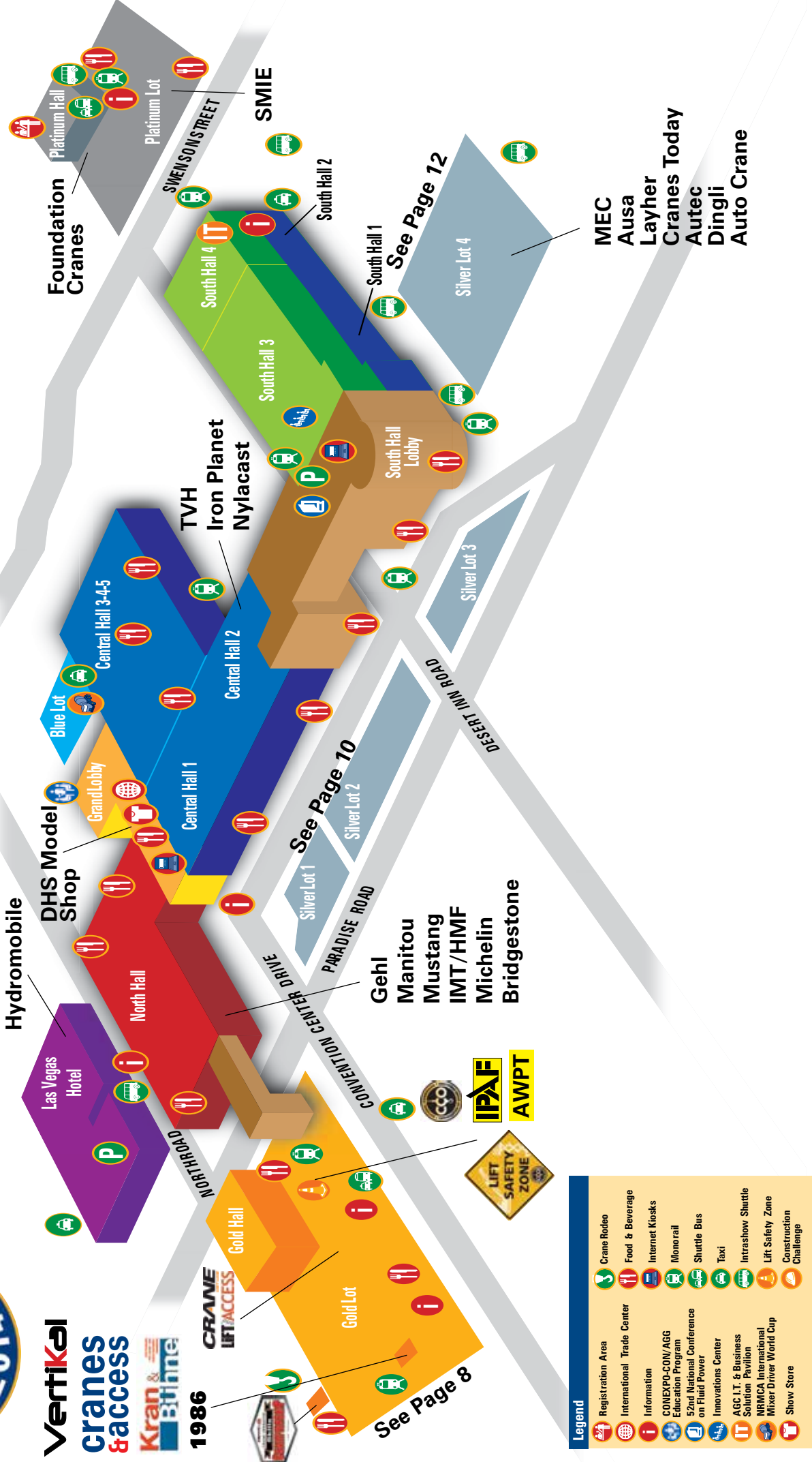

Legend	
	Registration Area
	International Trade Center
	Information
	CONEXPO-CON/AGG
	Education Program
	52nd National Conference on Fluid Power
	Innovations Center
	AGC I.T. & Business Solution Pavilion
	NRMCA International Mixer Driver World Cup
	Show Store
	Crane Rodeo
	Food & Beverage
	Internet Kiosks
	Mono rail
	Shuttle Bus
	Taxi
	Intrashow Shuttle
	Lift Safety Zone
	Construction Challenge

Haulotte range

BENEFITS your business



MARCH 4-8, 2014

Las Vegas

VISIT US AT:

IF IT'S NEW, IT'S HERE Gold Lot - Booth # 1531



Haulotte 
SERVICES

 TECHNICAL SUPPORT

 SERVICE SOLUTIONS

 SPARE PARTS

 TRAINING



Close to you, worldwide

Haulotte Group - 125 Taylor Parkway, Archbold, OH 43502 • Tel: +1 419 445 8915 - Toll Free: +1 800 537 0540

www.haulotte-usa.com

GOLD LOT

RIVERIA



Crane Operators Rodeo/Contest
 2975

GOLD LOT KEY

- ACCESS
- CRANES
- TELEHANDLERS
- COMPONENTS
- PUBLICATIONS & ASSOCIATIONS

Maxam Tire 2943

EPS 2965

2975

2979/2977

2973

2971

2967

2961

2955

2949

2943

2937

ReachMaster

Bluelift
Denka
Galizia
R&B
TCA
Winlet

2870
2771

2856
2858

2842

2836

2832

2826

Liebherr 2155

2744
2736

2715

2709

2703

Manitowoc
Grove
National Crane
Potain
CranitMAX 2137

2115

2109

2103

Kobelco Cranes 2129

Manitex
Valla
Badger 2115

ALLU 2109

Tadano Mantis 2101

Stand No.s 2000s

Vertikal
Tracked Lifts
Ommelift

cranes & access
Kran & Sittme

1986

1888

1882

1876

1870

1864

1858

1852

1846

1840

1834

REMUM 1587

XCMG 1579

JCB 1559

Link Belt 1747

Skyjack 1837

Morooka 1537

ALTEC 1827

YANMAR 1517

Doosan Bobcat 1501

IPAF 1817

Doosan Bobcat 1501

1594

1588

1582

1576

1570

1564

1558

1552

1546

1540

1534

1528

1492

1486

1480

1474

1468

1462

1456

1450

1444

1438

1432

1426

1395

1389

1383

1377

1371

1365

1359

1353

1347

1341

1335

1329

1292

1286

1280

1274

1268

1262

1256

1250

1244

1238

1232

1226

1097

1091

1085

1079

1073

1067

1061

1055

1049

1043

1037

1031

Stand No.s 1000s

Stand No.s 1000s

MARCH 4 - 8, 2014 • 9:00 AM - 5:00 PM TUESDAY - FRIDAY • 9:00 AM - 3:00 PM SATURDAY

REACHING NEW HEIGHTS



Terex works for you – taking you and your business higher with Terex® cranes and Genie® aerial work platforms.

When it comes to lifting, our reliable and versatile products together with our responsive customer support deliver the best solutions for your business success.

Contact us to learn how we can help you reach new heights:
www.terex.com/cranes and www.genielift.com



TEREX®

Genie®
A TEREX BRAND

SILVER LOTS 1 and 2

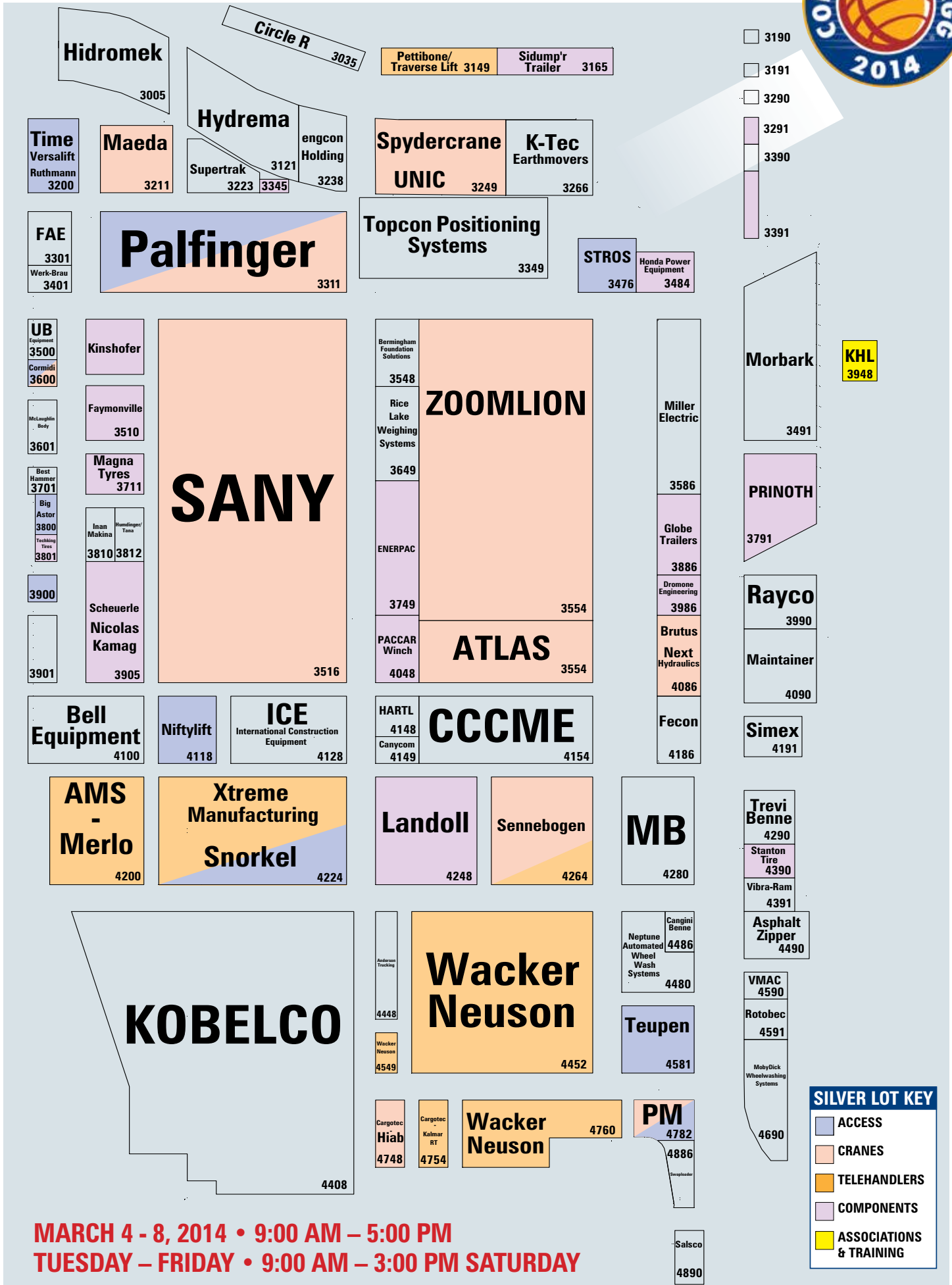

MARCH 4 - 8, 2014 • 9:00 AM – 5:00 PM
TUESDAY – FRIDAY • 9:00 AM – 3:00 PM SATURDAY

A nighttime view of the Las Vegas Strip from the perspective of a crane operator. The foreground shows the interior of the crane cab, including a large black fan on the right, two monitors, and control panels. The background is a vibrant cityscape with numerous illuminated buildings and signs, including the Flamingo Las Vegas, the Flamingo Las Vegas, the Flamingo Las Vegas, and the Flamingo Las Vegas. The Eiffel Tower replica is prominent in the distance.

Big things are arriving in Vegas.

New cranes, new technology and new solutions to grow your business.
You'll find it all at the Manitowoc booth. Don't miss it.

www.manitowoccranes.com/conexpo



Booth 2137, Gold Lot



SILVER LOT 4

SILVER LOT KEY

- ACCESS
- TELEHANDLERS
- ASSOCIATIONS & TRAINING
- CRANES
- COMPONENTS

Tiger Tool 6102	Gateway Safety 6110	Macro Physics 6116	Cranna Taps 6118	King Kong Tools 6122	Pro-Tec Equipment 6023	Speed Shore 6029	Southwest Products 6043	Knapheide 6055	Cross Country 6063	6073
EASI-POUR 6301	6210 6211	6215	6315 6218	National Attachments 6222		ESAB Welding and Cutting Products 6130	MEC 6148	Alliance Tire Americas 6158	Tigercat Industries 6166	6075
6401	Featherlite Trailers 6310	TT Technologies 6316		Rigid Lifelines 6329		Scrommel Reclaimers 6335	Brofil Clean Air Solutions 6339	ERMA-RTMO 6345	Kloekner Metals 6351	6076
6402		Hoist Lifftruck 6515	Valley Industries 6521	Rapid International 6430		Dingli 6445	Morris 6357	NLMK Clabecq 6365	6369	6173
6501								SEMPI M. 6465	6466 6472	6175
TREK 6601	Kaeser Compressors 6609	Terramite 6617		Loadcraft Industries 6629		Valm 6647	Rhino 6657	ICS 6665	Dromatic 6569	6373
Acrow Formwork 6702	Ramsey Industries Auto Crane 6710		Taylor Machine Works 6720		Alpha 6730	AUSA 6742	Ari-Hetra	SANKO 6766	6465	6376
Hilti 6901					Alkon 6831	Layher 6736	Pilosi 6048	Berg	6465	6376
	Daycab 6910	ESTI 6916	6920 6922 6924 6926	Blue Hat 6830	6832				6465	6376

MARCH 4 - 8, 2014 • 9:00 AM - 5:00 PM TUESDAY - FRIDAY • 9:00 AM - 3:00 PM SATURDAY

Crane and Access events at the show Crane Operators Skills Championship

18 crane operators will battle it out for the title of top crane operator in the Crane & Rigging Hot Line & CIC Skills Championship on Thursday and Friday March 6th and 7th. 16 of the operators qualified from regional heats held last year, while two additional operators will be selected from qualifying rounds on Tuesday and Wednesday March 4th and 5th on stand 2975 in the Gold Lot. Operators can pre-register for the qualifiers on www.craneoperatorrodeo.com. Contestants will use a 220 tonne/265 ton Liebherr LTM 1220-5.2 All-Terrain crane.

The Crane Operator Skills Championship is sponsored by Liebherr, Houston International Insurance, Slingmax, Crosby, Hirschmann, DICA Outtrigger Pads, and InfoChip. It is designed to recognise crane operators' skills, introduce the profession to young people and educate local governments and businesses on the role training, experience and certification plays in safe crane operation.

5K charity run

The five kilometre charity run or walk will be held on Wednesday March 5th, with funds raised going

to the Injured Marine Semper Fi Fund that provides financial relief to injured members of the US armed forces and their families during hospitalisation and recovery and ongoing needs. Guy Ramsey of race organiser Maximum Capacity Media said: "We hope to raise at least \$10,000 for the fund. In 2011 the event had almost 250 runners, and I envision that number swelling to 400."

Registration: \$25 before 2/14/2014 - \$30 onsite - all participants will receive an event T-shirt

Start Time: 7:00 - arrive early to pick up your shirt

Start point: Below sign for the LVH Hotel & Casino (Formerly the Las Vegas Hilton) 3000 Paradise Road

Lift safety Zone

The National Commission for the Certification of Crane Operators (NCCCO) will host practical and written crane operator certification exams, it will share a stand with the International Powered Access Federation (IPAF) which will be stressing the importance of understanding the risks of working near overhead power lines.

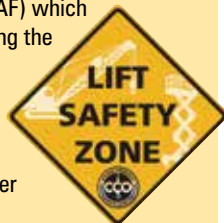

Eventos de grúas y plataformas en la feria Campeonato de habilidades de operador de grúa

18 operadores de grúas se enfrentarán por el título de mejor operador de grúa en el campeonato de Habilidades Crane & Rigging Hot Line



& CIC el jueves 6 y el viernes 7 de marzo. 16 de los operadores fueron calificados de eliminatorias regionales celebradas el año pasado, mientras que dos operadores adicionales serán seleccionados de rondas de clasificación el martes y el miércoles 4 y 5 de marzo en el stand 2975 en el Gold Lot. Los operadores pueden pre-registrarse para la fase de clasificación en www.craneoperatorrodeo.com. Los concursantes utilizarán una grúa todo terreno Liebherr LTM 1220-5.2, de 265 toneladas.

El campeonato de habilidades de operador de grúa tendrá el patrocinio de Liebherr, Houston Insurance International, Slingmax, Crosby, Hirschmann, DICA Outtrigger Pads e InfoChip. Está diseñado para reconocer la competencia de los operadores de grúa.

Carrera CONEXPO-CON/AGG 5K

La carrera por la caridad de cinco kilómetros a pie tendrá lugar el

miércoles 5 de marzo, con los fondos recaudados que irán al Fondo de Injured Marine Semper Fi.

Inscripción: \$25 antes de 2/14/2014 - \$30 en el lugar - todos los participantes recibirán una camiseta del evento.

Hora de inicio: 7:00 - llegar temprano para recoger su camiseta.

Punto de inicio:

Debajo del cartel del LVH Hotel & Casino (Previamente Las Vegas Hilton) - 3000 Paradise Road.

Zona de seguridad de plataformas

La Comisión Nacional para la Certificación de Operadores de Grúa (NCCCO) será la sede de los exámenes de certificación escrita y práctica de operador de grúa, que compartirá un stand con la Federación Internacional de Acceso Motorizado (IPAF), que subraya la importancia de comprender los riesgos de la sobrecarga de trabajo, cerca de líneas de alta tensión.



PLA^TFORM BASKET



platformbasket.com



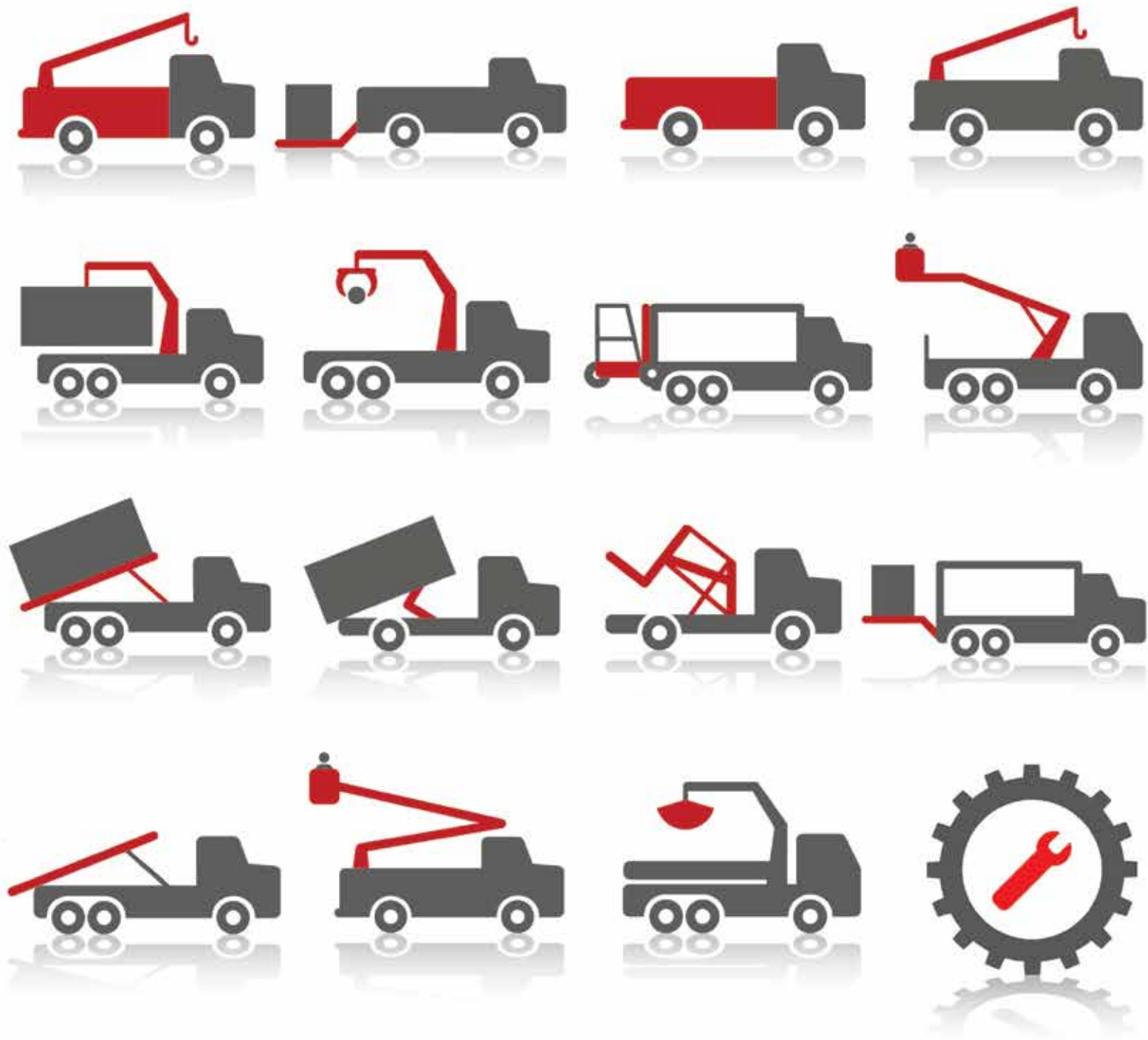

PALFINGER **PRODUCT RANGE**

PALFINGER

LIFETIME EXCELLENCE

PALFINGER offers the most **EFFICIENT**, **RELIABLE** and **INNOVATIVE** product range to satisfy your lifting, loading and handling needs across North and Latin America. Expect **LIFETIME EXCELLENCE** with PALFINGER knuckle boom and service cranes, truck-mounted fork-lifts, aerial work platforms, container handling solutions, work-truck bodies, liftgates and more!

See our product range for yourself in Booth #3311!

WWW.PALFINGER.COM

	STAND	HALL/LOT
Self-propelled Booms Plataformas autopropulsadas		
Bil-Jax	1531	Gold
Dingli	6445	Silver 4
Haulotte	1531	Gold
Genie	1047	Gold
JLG	1037	Gold
Manitou	12605	North
MEC	6148	Silver 4
Niftylift	4118	Silver 1
PB Lifetechnik	2765	Gold
Skyjack	1837	Gold
Snorkel	4218	Silver 1
Tadano	2101	Gold
Mast Booms • Elevadores de Mástil		
Dingli	6445	Silver 4
Genie	1047	Gold
Haulotte	1531	Gold
JLG	1037	Gold
Manitou	12605	North
Snorkel	4218	Silver 1
Push Around lifts Elevadores de empuje manual		
Bil-Jax	1531	Gold
Custom Equipment	1725	Gold
Dingli	6445	Silver 4
Genie	1047	Gold
Haulotte	1531	Gold
Pop-Up /Snorkel	4218	Silver 1
JLG	1037	Gold
Skyjack	1837	Gold
Snorkel	4218	Silver 1
Scissor Lifts • Plataformas de Tijera		
Custom Equipment	1725	Gold
Dingli	6445	Silver 4
Genie	1047	Gold
Haulotte	1531	Gold
JLG	1037	Gold
Manitou	12605	North
MEC	6148	Silver 4
PB Lifetechnik	2765	Gold
Skyjack	1837	Gold
Snorkel	4218	Silver 1
Spider and Trailer lifts Plataformas de Araña y remolcables		
Bil-Jax	1531	Gold
Blue Lift	2765	Gold
Cormidi	3600	Silver 1
Denka	2765	Gold
Genie	1047	Gold
Haulotte	1531	Gold
Hinowa - JLG badged	1037	Gold
Jekko	1095	Gold
JLG	1037	Gold
Niftylift	4118	Silver 1
Oil&Steel	4782	Silver 1
Omme Lift	2084	Gold
Platform Basket	2084	Gold
ReachMaster	2765	Gold
Snorkel	4218	Silver 1
TCA Lift	2765	Gold
Teupen	4581	Silver 1
Tracked Lifts	2084	Gold
Truck mounted lifts Plataformas sobre camión		
Altec	1827	Gold
Condor	3200	Silver 1
Elliott Equipment	1108	Gold
ETI	3311	Silver 1
Hydra	1047	Gold
Manitex	21115	Gold
Oil & Steel	4782	Silver 1

	STAND	HALL/LOT
Palfinger	3311	Silver 1
Ruthmann	3200	Silver 1
Tadano	2101	Gold
Terex Utilities	1047	Gold
Teupen	4581	Silver 4
Time	3200	Silver 1
Versalift	3200	Silver 1
Mastclimbers & Hoists Plataformas de másti		
Geda	53090	Central
Hydro Mobile	608	Hotel
Raxtar	608	Hotel
STROS	3476	Silver 1
All Terrain/Truck Cranes Grúas todo terreno		
Altec	1827	Gold
Elliott Equipment	1108	Gold
Grove	2137	Gold
Liebherr	2155	Gold
Link-Belt	1747	Gold
Little Giant	2155	Gold
Manitex	2155	Gold
National Crane	2137	Gold
Palfinger	3311	Silver 1
Sany	3516	Silver 1
Tadano	2101	Gold
Terex	1047	Gold
XCMG	1579	Gold
Zoomlion	3554	Silver 1
Crawler Cranes • Grúas de celosía		
Bauer	7038	Platinum
Casagrande	8254	Platinum
Hitachi - See Link-Belt	1747	Gold
Kobelco Cranes	2129	Gold
Lampson International	1392	Gold
Liebherr	2155	Gold
Link-Belt	1747	Gold
Maeda	3211	Silver
Mait	7854	Platinum
Manitowoc	2137	Gold
Mantis (Tadano)	2101	Gold
Sany	3516	Silver 1
Sennebogen	4264	Silver 1
Soilmec	9454	Platinum
Tadano	2101	Gold
Terex	1047	Gold
XCMG	1579	Gold
Zoomlion	3554	Silver 1
Pick & Carry Cranes		
Broderson	1324	Gold
Galizia	2765	Gold
Grove	2137	Gold
Jekko	1095	Gold
JMG	2309	Gold
Liebherr	2155	Gold
Shuttlelift	1395	Gold
Terex	1047	Gold
Valla	2115	Gold
Rough Terrain Cranes Grúas para terrenos accidentados		
Badger	2115	Gold
Global Cranes	3554	Silver 1
Grove	2137	Gold
Kobelco Cranes	2129	Gold
Link-Belt	1747	Gold
Sany	3516	Silver
Tadano	2101	Gold
Terex	1047	Gold
XCMG	1579	Gold
Zoomlion	3554	Silver 1

	STAND	HALL/LOT
Spider Cranes • Grúa Araña		
Cormidi	3600	Silver 1
Jekko	1095	Gold
Maeda	3211	Silver 1
Mighty Crane	2765	Gold
R&B Engineering	2765	Gold
Reachmaster	2765	Gold
Spydercrane Sales	3249	Gold
Unic	3249	Silver 1
Tower Cranes • Grúas Torre		
Comansa	2181	Gold
Comedil - Terex	1047	Gold
Liebherr	2155	Gold
Linden Comansa	2181	Gold
Manitowoc	2137	Gold
Potain	2137	Gold
Terex	1047	Gold
Zoomlion	3554	Silver 1
Loader Cranes/Boom trucks Grúas remolcables		
Altec	1827	Gold
Atlas	3554	Silver 1
Auto Crane	6710	Silver 4
Cargotec, Hiab	4748	Silver 2
Elliott Equipment	1108	Gold
Fassi	2736	Gold
Furakawa-Unic	3249	Silver 1
Hiab	4748	Silver 2
HMF	10652	North
Iowa Mold Tooling	10652	North
Manitex	2155	Gold
Maxilift	4086	Silver 1
National Crane	2137	Gold
Next Hydraulics - Brutus	4086	Silver 1
Palfinger	3311	Silver 1
PM	4782	Silver 1
Service Trucks International	1310	Gold
Stellar Industries	1406	Gold
Tadano	2101	Gold
Terex	1047	Gold
Telehandlers • Manipuladores Telescópicos		
Ausa	6736	Silver
Bobcat	1501	Gold
Case	11722	North
Caterpillar	1005	Gold
Dieci	2175	Gold
Doosan	1501	Gold
Gehl	12605	North
Genie	1047	Gold
Haulotte	1531	Gold
JCB	1559	Gold
JLG	1037	Gold
Liebherr	2155	Gold
Lull	1037	Gold
Magni	2115	Gold
Manitou	12605	North
Merlo	4200	silver 2
Mustang	12605	North
Pettibone	3149	Silver 1
Sellick	1071	Gold
Sennebogen	4264	Silver 1
Skyjack	1837	Gold
SkyTrak	1037	Gold
Snorkel	4224	Silver 2
Terex	1047	Gold
Wacker Neuson	4452	silver 2
Xtreme	4224	silver 2
Trailers • Remolques		
Cometto	244	Hotel
Faymonville	3510	Silver 1
Goldhofer	2836	Gold
Kamag	3905	Silver 3
Landoll trailers	4248	Silver 1

IMO SLEW DRIVES

made in Gremsdorf, Germany.



Reliability [total]:

more than **100,000** Slew Drives since 1994

Way up in the sky or down under bridges...
IMO Slew Drives ensure your fleet's top performance through its service life. Applying highest safety standards at a low-cost, reliable solution.

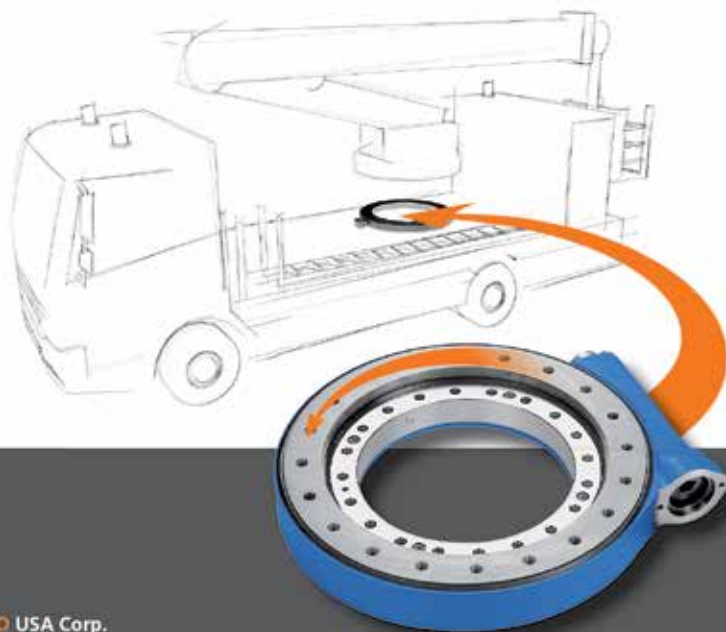

Our Slew Drives are completely enclosed worm drive units, ready to install. The precision of the drive virtually eliminates drift. **IMO** is the leading manufacturer of Slew Drives - available in a wide variety of base models (output torque 3.28 kNm / 2,420 ft-lbs to 446 kNm / 329,320 ft-lbs)

IMO USA Corp.

4000 Faber Place Drive
Suite 300
North Charleston
SC 29405 USA
Tel. +1 843 695-6200
americas@imo.us

www.imo-lifting.com



Booth
2084

RENTAL READY ACCESS...

I NEED TO REACH HEIGHTS OF 100 FT. TO HANG THE DISPLAY MATERIAL

IT NEEDS TO WORK ON THE SLOPE OUTSIDE

...AND PASS THROUGH THE SIDE ENTRANCE

...AND IT CAN'T MARK THE TILED FLOOR

HMM...WHAT WILL DO THE JOB?

I KNOW...AN OMMELIFT 3150!

WINTER SALE

IT CAN ALSO BE USED INDOOR FOR CLEANING THE ATRIUM, AND UPPER-LEVEL MAINTENANCE

BETTER CONTACT MY OMMELIFT PROVIDER...



FIND YOUR DEALER ON OMMELIFT.COM

OMMELIFT A/S, Lægårdsvej 4,
7260 Sdr, Omme, Denmark

LIST OF EXHIBITORS ■ LISTA DE EXPOSITORES

	STAND	HALL/LOT
Trailers • Remolques		
Ledwell	61409	South
Load King	2155	Gold
Nelson trailer	2374	Gold
Nicolas Industrie.	3905	Silver 1
Scheuerle	3905	silver 1
Talbert	2474	Gold
XL trailers	2744	Gold
Remote Controls • Control Remoto		
Autec	6773	Silver 4
HBC-radiomatic	52872	Central
Hetronic	1171	Gold
Ikusi	82918	South
Scanreco	3291	Silver 1
Tele Radio	760	Hotel
Electronics & Safety		
3B6/Cobo	85201	South
Ascorel	50963	Central 3
Cobo	85201	South
Curtiss Wright Controls	83434	South
Cranesmart Systems	1393	Gold
Deltatech controls	84034	South
GKD Technik	40424	Central
Hirschmann (PAT)	2024	Gold
Hoistcam	90427	Platinum
HookCam	2674	Gold
Load Systems International	2761	Gold
Moba	50063	Central
NBB Controls	50932	Central
OEM Controllers	80707	South
Orlaco	2771	Gold
PAT	2024	Gold
Penny & Giles	83434	South
P-Q Controllers	82021	South
Rayco Wylie	2755	Gold
Sigalarm	70112	Gold Hall
SMIE	8676	Platinum
Trimble	61046	South 1
Tires/Tyres • Neumáticos		
BKT Tires	70050	Gold Hall
Bridgestone	13006	North
Continental Tire	9494	Platinum
Double Coin tires	65401	Silver 4
Goodyear	11649	North
Magna Tyres	3711	Silver 1
Michelin	10378	North
Solideal-Complast	40322	Central
Titan Tire and Wheel	11671	North
Yokohama Tire	30412	Central
Engines • Motores		
Cummins	84808	South
Deutz	84620	South
Hatz Diesel	83740	South
Honda	84030	South
Kohler	7127	Platinum
Kubota	84608	South
MTU	84630	South
Perkins/Cat	84318	South
Yanmar	11671	North
Components • Componentes		
ADB Slew rings	70049	Gold Hall
Allison Transmission	85430	South
Auburn Gear	8111	South
Axle Tech	84830	South
Bonfiglioli Riduttori	80642	South
BorgWarner	85408	South
Bosch Rexroth	80216	South
Brand Hydraulics	81507	South
Brevini	2971	Gold
Bucher Hydraulics	82829	South
BVA Hydraulics	82740	South
Changzhou Aoxuan Slew Ring	508	Hotel
Comer	82130	South
Concentric Rockford	80908	South
Dakota Fluid Power	83344	South
Dana	85114	South

	STAND	HALL/LOT
Danfoss	80529	South
Dinamic Oil	83640	South
DLH fluid power	81818	South
Donaldson filter	83940	South
Dynamic Fluid Components	82818	South
Eagle Hydraulics	81511	South
Eaton	80230	South 3
Fairfield	81529	South
Force America	82522	South
Gardner Denver	64015	South
Gates	80516	South
Grear	83130	South
HAVE Hydraulics	81215	South
HBS	8576	Platinum
Helac	30934	Central 1
Hunger Hydraulics	82212	South
Hydraforce	80930	South
Hydrocontrol	82507	South
Hydratech pumps	85318	South
Kessler	83501	South
KTI Hydraulics	81922	South
Ligon	83122	South
Linde Hydraulics	81318	South
Lube-A-Boom	1888	Gold
Maanshan Fang Yuan Slewing Ring	53145	Central
Magantek	81147	South
Manuli Hydraulics	81708	South
Marooka	1537	Gold
North American Hydraulics	82620	South
Nylacast	40527	Central
Oerlikon Fairfield	81529	South
Omni Gear	83534	South
Parker Hanifin	80440	silver 3
Pirtek	8224	Platinum
Poclain Hydraulics	80940	South
Ramsey Industries	6710	Silver 4
Reel-O-Matic	1888	Gold
Rexroth	80216	South 3
Ryco Hydraulics	82018	South
SAI Hydraulics	82530	South
Sauer-Danfoss	80529	South
Solideal	40322	Central
Spartan Mats	6576	Silver 4
SSAB	30611	Central 1
Sun Hydraulics	80719	South
Texas Hydraulics	81618	South
Tieffe	83418	South
Trelleborg	81929	South
TWG - Tulsa Winch	83130	South
Warn	453	Hotel
Weber Hydraulik	83108	South
White Drive	81107	South
Yates Industries	81921	South
ZF	85030	South
Lifting Equipment • Equipos de elevación		
Allied Power Products	70141	Gold Hall
Altumamats	61419	South 1
Big Astor	3800	Silver 1
Braden winch	4048	Silver 1
Bridgwell Mats	51104	Central
Caldwell	30313	Central
Crosby	30334	Central
DICA	63731	south
Enerpac	3749	Silver 1
Gearmatic	4048	Silver 1
GKS Lifting and Moving	90527	Platinum
Groundmats	9600	Platinum
Gunnebo Johnson	2842	Gold
Harrington Hoists	70306	Gold Hall
Industrial Lift and Hoist	1421	Gold
Kinshofer	3510	Silver 1
Lift Systems	1097	Gold
LGH	3345	Silver 1
Lifting Technologies	2979	Gold
Miller Lifting	2854	Gold
Nylacast	40527	Central
Quality Mat Co	30303	Central 1
Rotzler	81419	south
RUD Chain	70332	Gold Hall
Spanco	61542	Platinum
Sumner	50930	Central
Taylor	6720	Silver 4
Winlet	2765	Gold

	STAND	HALL/LOT
Wire Rope • Cables		
Alpwire	70043	Hotel
Associated Wire Rope & Rigging	2852	Gold
Bridon	52828	Central
Casar	50040	Central
Teufelberger Seil	614	Hotel
Wire Co	50040	Central
Wirerope Works	70209	Gold
Associations & training • Asociaciones		
AEM	20051	G Lobby
ANMOPyC	20030	G Lobby
ASME	20039	G Lobby
bauma 2016	40312	G Lobby
Bices	20040	G Lobby
CEA	40424	Central
China Const. Machinery Assoc.	20042	G Lobby
Crane Institute of America	2973	Gold
Cranes Institute Certification	2975	Gold
Indian Const. Machinery Assoc	20107	G Lobby
Intermat 2015	20074	G Lobby
IPAF	1817	Gold
NCCCO	1817	Gold
NACB	2870	Gold
Int. Union of Operating Engineers	20125	G Lobby
Operating Engineers Training Ont.	70034	Gold Hall
OSHA training	349	Hotel
SC&RA	20032	G Lobby
Scaffold & Access Ind. Assoc.	60127	South 1
Dealers & Rental		
Big Astor	3800	Silver 1
Blue Hat Hoisting	6830	Silver 4
Fascan	2736	Gold
F&M Mafco	65009	South
Lampson	1592	Gold
Lifting Gear Hire	3345	Silver 1
PVE Cranes & Services	8023	Platinum
Spydercrane sales	3249	Silver 1
Titan Machinery	7051	Platinum
Tracked Lifts	2084	Gold
Scaffold & Ladders		
Bil-Jax	1531	Gold
EZ Scaffold	2977	Gold
Layher	6842	Silver 4
Little Giant Ladder	130	Hotel
Pilosio	6848	Silver 4
Software		
3D Lift Planner	2853	Gold
A1A	2853	Gold
Automation Studio	80497	South
CraniMax	2137	Gold
Lo-Jack	70003	Gold Hall
Sage	65320	South
Other		
Crane Hot Line	2975	Gold
Crane Network	2975	Gold
Cranes & Access	1986	Gold
Crane & Hoist Canada	1568	Gold
Cranes Today Magazine	6209	Silver 4
DHS Diecast collectibles	20012	G Lobby
Equipment Parts Wholesale	2965	Gold
Historical Cons. Equip. Ass.	20012	G Lobby
IronPlanet	40064	Central 1
KHL	3498	Silver 1
Kran & Bühne	1986	Gold
Lectura Verlag	60110	South L
Mascus	20139	G Lobby
Maximum Capacity Media	2975	Gold
MinnPar	30720	Central
Morooka	1537	Gold
Off-Highway Research	40519	Central
Prinorth	3791	Silver 1
Rental Equipment Register	20110	Grand
Lobby		
Tenstar Simulation	62750	South
TVH	40216	Central 1
Tyri Lights	61455	South
Vertikal.Net	1986	Gold
Wells Fargo Finance	11758	North

ALL TERRAIN/TRUCK CRANES ■ GRÚAS TODO TERRENO/GRÚAS SOBRE CAMIÓN

Manufacturer • Fabricante	Stand	Lot
Altec	1827	Gold
Elliott Equipment	1108	Gold
Grove	2137	Gold
Liebherr	2155	Gold
Link Belt	1747	Gold
Little Giant	2155	Gold
Manitex	2155	Gold
National Crane	2137	Gold
Palfinger	3311	Silver 1
Sany	3516	Silver 1
Tadano	2101	Gold
Terex	1047	Gold
XCMG	1579	Gold
Zoomlion	3554	Silver 1

There are plenty of All Terrain and truck cranes to see this year, most of them in the Gold Lot, where we begin our tour next to the Vertical stand with XCMG.

The Chinese manufacturer has several new cranes aimed at the North American market, including the 90 tonne XCT90U five axle truck crane.

We cross the corner of the JCB stand to **Liebherr** - the world's largest producer of All Terrain cranes - showing what is probably the largest AT at the show - the surprisingly popular 750 tonne LTM 1750-9.1 launched at Bauma, which has been selling extremely well in Europe. Alongside is the 300 tonne single engine, six axle LTM 1300-6.2. You might also make a short detour to the **Crane Operators Rodeo Contest** to the rear where 18 operators will battle it out for the title of top crane operator using a 220 tonne Liebherr LTM 1220-5.2 All Terrain crane.

Next door **Manitowoc/Grove** is promising several major crane

Grove GMK 6400



launches at the show. We do know that it will have the 300 tonne GMK6300L and the 400 tonne GMK6400 ATs on the stand, as well as two **National Crane** truck mounts, including its largest crane to date - the NBT60. With a 54.4 tonne capacity, 39 metre five section, full power boom and 13.7 metre two section offsettable extension. Despite its size it is said to be roadable without additional permits across the USA.

On the opposite side of the aisle **Link-Belt** is unveiling a new 185 tonne, five axle ATC-3210, its second All Terrain crane built specifically for the North American market, joining the larger ATC-3275 launched in 2011. Check out its new counterweight design and easy roading features, export versions will be available later this year.

We now walk a few steps to the **Terex** stand to see its latest All



Liebherr LTM1300

Terrain crane - the Explorer 5800 - and take a look at the company's largest boom-truck type truck mount to date. The company is also likely to have one or two other surprises up its sleeve - so well worth the minor detour.

Now cross the Marooka stand to **Altec** which is launching its new 45 ton AC45-127S truck crane/boom-truck with all new cab and load management system. Across the aisle is fellow boom truck specialist **Manitex**, now a growing international crane manufacturer, where you will find the largest commercial truck mount at the show, the 70 tonne Manitex TC700 with 55 metre maximum tip height. The group also produces the **Little Giant** lattice boom truck cranes for specific applications.

Continuing down the aisle brings you to **Tadano** where you will have the chance to see the largest All Terrain crane in the company's range, the 400 tonne six axle ATF 400G-6 launched at Bauma last year. Just before leaving the Gold Lot stop off at **Elliot Equipment** to see the company's new 41 tonne 41452 truck crane with 43 metre, five section main boom.

Crossing the road to the Silver Lot you cannot miss Chinese manufacturer **Sany**, which has one of the biggest stands at the show. Sany North America has undergone massive management changes in

recent months, and was unable to reveal the products it will show, but it offers both All Terrain and truck cranes, including the 1,000 tonne AT the SAC 12000.

Across the aisle you will find fellow Chinese manufacturer **Zoomlion** which so far has not promoted its road going cranes in North America, but it does produce a wide range of All Terrains and truck mounted cranes, including the world's largest AT - the 2,000 tonne QUAY2000. You might also get a chance to see the new 130 tonne QY130 six axle truck crane



Altec AC45-127S



Manitex TC700



Tadano ATF400G-6



Liebherr LTM 1750-9.1

Hay un montón de grúas todo terreno y grúas sobre camión para ver este año, la mayoría de ellos en el Gold Lot, donde comenzamos nuestro recorrido junto al stand de Vertikal con XCMG.

El fabricante chino tiene varias grúas nuevas destinadas al mercado de América del Norte, incluyendo la grúa sobre camión XCT90U, de 90 t de capacidad con cinco ejes. Cruzamos la esquina de JCB hacia el stand de Liebherr, el mayor productor del mundo de grúas todo terreno - que muestra lo que es probablemente la grúa AT más grande de la feria - su sorprendentemente popular LTM 1750-9.1 de 750 toneladas lanzada en Bauma, que se ha estado vendiendo muy bien en Europa, junto con la grúa de 300 t con motor único en seis ejes, la LTM 1300-6.2. También puede tomar un pequeño desvío al concurso de Rodeo de operadores de grúas en la parte trasera, donde 18 operadores se enfrentarán por el título de mejor operador de grúa. Los concursantes utilizarán una grúa Liebherr LTM 1220-5.2 de 220 toneladas.

Al lado Manitowoc/Grove ha prometido varios lanzamientos de grúas grandes en la feria, pero se negó a dar ninguna pista antes de la feria. Sí sabemos que va a tener la GMK6300L, de 300 toneladas y la GMK6400, de 400 toneladas, así como dos grúas sobre camión de National Crane, la NBT15 y su mayor

grúa hasta la fecha, la NBT60. Con una capacidad de 54,4 toneladas, cuenta con una pluma de 39 metros y cinco secciones, y extensión de 13,7 metros de dos secciones. A pesar de su tamaño, se dice que puede ser conducida sin permisos adicionales en los EE.UU.. En el lado opuesto del pasillo Link-Belt está presentando una nueva grúa de 185 toneladas, de cinco ejes, la ATC- 3210, su segunda grúa todo terreno construida específicamente para el mercado de América del Norte, uniéndose a la ATC-3275 que se puso en marcha en 2011. Eche un vistazo a su nuevo diseño de contrapeso y características de transporte fáciles, las versiones de exportación estarán disponibles a finales de este año.

Ahora caminamos a unos pasos a Terex, para ver su última grúa todo terreno - la Explorer 5800, y eche un vistazo a la grúa sobre camión más grande de la empresa hasta la fecha. La compañía también es probable que tenga una o dos sorpresas en la manga - tan bien vale la pena una parada.

Ahora cruce el stand de Marooka hacia Altec que está lanzando su nueva grúa sobre camión de 45 ton con la cabina toda nueva y el sistema de gestión de carga. Al otro lado del pasillo está Manitex, un fabricante cada vez más internacional de grúas, donde encontrará la grúa más grande sobre camión comercial hasta la fecha, el



Liebherr LTM 1300



Link Belt ATC 3210



Grove GMK 6300 L

Ahora cruzamos la carretera al Silver Lot donde no se puede perder el fabricante chino Sany, que tiene uno de los mayores stands de la feria. Sany América del Norte ha experimentado cambios de gestión masivos en los últimos meses y se mantiene en silencio sobre los productos que se mostrarán pero ofrece tanto grúas todo terreno como grúas sobre camión, incluyendo la SAC 12000 de 1000 t. Al otro lado del pasillo se encuentra el fabricante chino Zoomlion que hasta ahora no se ha decantado por las grúas de conducción en América del Norte, pero sí produce una amplia gama de todo terreno y camiones grúas, incluyendo la más grande del mundo - la QUAY2000, de 2000 t. También podrá tener la oportunidad de ver la nueva grúa de 130 toneladas de seis ejes QY130 de camión grúa.

Manitex TC700, con 70 toneladas y 55 metros de altura máxima en punta. El grupo también produce las grúas de celosía Little Giant para aplicaciones específicas.

Continuando por el pasillo que lleva a Tadano, tendrá la oportunidad de ver la mayor grúa todo terreno de gama de la compañía, la de 400 toneladas de seis ejes, modelo ATF 400G - 6 presentada en Bauma año pasado. Antes de abandonar el Gold Lot pare en Elliot Equipment para ver el nuevo 41452 de 41 toneladas de la empresa con 43 metros de pluma y cinco secciones.



National Crane N 60



Terex Crossover 4500



Visit us at Booth 3554
Silver Lot 1

The Wait is Over...Entire 2014 Zoomlion Line at ConExpo



- *Highest Quality, Lowest Priced RT's in the WORLD!!!*
- *Come see the Entire Line at ConExpo - Get Your Meeting NOW*
- *All Models Available in Los Angeles, Houston, Savannah*

Contact Details

Ed Gibson
(310) 749-0634

egibson@globalcranesales.com

Uri Toudjarov
(602) 320-0762

uri@globalcranesales.com

www.globalcranes.com

Manufacturer • Fabricante	Stand	Lot
Badger	2115	Gold
Global Cranes	3554	Silver 1
Grove	2137	Gold
Kobelco Cranes	2129	Gold
Link Belt	1747	Gold
Sany	3516	Silver 1
Tadano	2101	Gold
Terex	1047	Gold
XCMG	1579	Gold
Zoomlion	3554	Silver 1



Link-Belt RTC 80150



XCMG RT70U

As a product of the Americas, it is no surprise that Rough Terrain cranes are well represented at Conexpo.

We begin our tour on the **Terex** stand where you can see an updated version of its 100 tonne Quadstar 1100 RT which features the latest cab as well as improvements to maintenance access and reliability. Cross the JCB stand to **XCMG** to see its new 63.5 tonne/70ton RT70U which features a 43.2 metre main boom and has been designed specifically for the American market. You might also ask about the world's largest RT - the 200 tonne two axle RT200 launched in 2012, but unlikely to be displayed. Walk down the main aisle to **Link-Belt** which is unveiling a new 135 tonne three axle crane,



Zoomlion RT100

the RTC-80150 Series II with 59.5 metre six section main boom and 78.6 metre maximum tip height. The crane includes a new three position outrigger system it calls Confined Area Lifting Capacity (CALC).

Cross the aisle to **Manitowoc** to see

its latest Grove models - RT540E and RT770E - it may also have a new RT among its secret product launches? Next check in on **Kobelco** just in case it has any RTs on show before reaching the **Manitex** stand, to see the new **Badger** compact, cab-down RT cranes. At the end of the aisle **Tadano** is launching its new 145 tonne three

axle GR 1600XL-2. Two units will be on show of which one will be displayed in transportation mode. Features include a 61 metre six section boom with a rounded profile and single telescope cylinder.

We now cross the road to the Silver

Lot where **Sany** is displaying its four model RT range topped, by its latest addition the 77 tonne SCC 865 with five section 45 metre main boom. Over the aisle **Zoomlion** and distributor **Global Cranes** is showing its latest 2014 Rough Terrains, including the 65 tonne RT65 which has a longer boom and significantly better load chart, the RT40, RT75 and its largest - the RT100.



Badger CD4415



Badger CD4415

Como producto de América, no es de extrañar que las grúas todo terreno lentas estén bien representadas en CONEXPO.

Comenzamos nuestro recorrido en el stand de **Terex** donde se puede ver una versión actualizada de su QuadStar 1100 RT de 100 toneladas de capacidad, que cuenta con su cabina más moderna, así como mejoras en el acceso, el mantenimiento y la confiabilidad. Ahora cruza de JCB hacia **XCMG** para ver su nueva RT70U de 63.5 tonne / 70 ton que cuenta con una pluma principal de 43,2 metros y ha sido diseñada específicamente para el mercado americano, también puede preguntar acerca de la RT más grande del mundo - la RT200, de 200 toneladas de dos ejes que lanzó en 2012, pero es

poco probable que esté en la feria. Caminamos por el pasillo principal de **Link-Belt**, donde el fabricante de América del Norte está presentando una nueva grúa de tres ejes de 135 toneladas, la RTC- 80150 Serie II, con pluma principal de 59,5 metros de seis secciones y una altura máxima en punta de 78,6 metros. La grúa incluye un nuevo sistema de fijación de los estabilizadores de tres posiciones que denominado área confinado de Capacidad de elevación (CALC).



Grove RT770E

Cruza el pasillo para **Manitowoc** para ver sus últimos modelos Grove - RT540E y RT770E - y ¿podría tener un nuevo RT entre sus lanzamientos secretos de productos? A continuación, compruebe el stand de **Kobelco** por si acaso tiene algún RT en demostración. Antes de llegar al stand de **Manitex**, pare para ver las nuevas máquinas compactas Badger, con cabina hacia abajo. Al final del pasillo **Tadano** lanza su nueva GR 1600XL - 2 de 145 toneladas de tres ejes. Dos unidades se podrán ver en el modo de transporte. Las características incluyen una pluma de 61 metros de seis sección con un nuevo perfil redondeado y altura en punta de 78 metros.

Ahora cruzamos la carretera al Silver Lot donde **Sany** está mostrando su gama RT de cuatro modelos coronada por su más reciente adición de 77 toneladas, la SCC 865 con pluma de cinco sección de 45 metros. Al otro lado del pasillo **Zoomlion** y su distribuidor **Global Cranes** está mostrando sus últimas grúas de 2014, incluyendo

el la RT65, de 65 toneladas, que tiene una pluma más larga y significativamente mejor tabla de carga. También puede mostrar la RT40, RT60 y su grúa más grande - la RT100.



Zoomlion



Tadano GR1600XL

Manufacturer • Fabricante	Stand	Lot
Bauer	7038	Platinum
Casagrande	8254	Platinum
Hitachi - See Link Belt	1747	Gpld
Kobelco Cranes	2129	Gold
Lampson International	1392	Gold
Liebherr	2155	Gold
Link Belt	1747	Gold
Maeda	3211	Silver
Mait	7854	Platinum
Manitowoc	2137	Gold
Mantis (Tadano)	2101	Gold
Sany	3516	Silver 1
Sennebogen	4264	Silver 1
Soilmec	9454	Platinum
Tadano	2101	Gold
Terex	1047	Gold
XCMG	1579	Gold
Zoomlion	3554	Silver 1



Terex Superlift 3800

crawler, the TCC500 taking the company's range to three models. Targeting the utility market the new crane has a 33.5 metre four section boom.

We now cross the aisle to **Manitowoc** which has promised to unveil an "exciting new range of large lattice-boom crawler cranes" at the show. We do know that the new 165 tonne MLC165 will make its US debut and that it will be joined by two completely new crawler cranes but that's all we know, so definitely worth a stop. The MLC165 launched last year at Bauma is a 'global' crane designed to be easy to transport, fully self-rigging and aimed at general contractors, bridge builders, steel erectors and pile-driving. Maximum boom length is 84 metres and with optional fixed or luffing jibs maximum system length is 102.8 metres.



Kobelco CK1600G

Conexpo is usually an excellent show for crawler crane introductions and innovations and this year is no exception with plenty to see and several exciting new products. Most of the all - new introductions are telescopic models, but we are also likely to be surprised with some new conventional models.

We begin our tour in the Gold Lot on the **Liebherr** stand where you may find the largest crawler crane in Las Vegas - a 1,100 tonne LR11000. Introduced two years ago it will also be available with the company's Power Boom system boosting capacities. While clearly a massive crane it has been designed to be compact enough for use in constricted areas. Liebherr will also

show a 250 tonne LR 1250 with its three metre transport width and wide variety of options to suit a multitude of applications.

Now head past JCB towards the Vertikal stand and you will find Chinese crane maker **XCMG** will show a new version of its 80 tonne QUY80 the QUY80U, and possibly one other. The company has been targeting the top end of the crawler crane market but has done little outside of China. Now cut behind JCB to **Terex** where you will find the 650 tonne Superlift 3800, the long awaited successor to the CC2800 series. Unveiled a year and half ago, this is the first opportunity to see the new crane in North America. We now head to **Link Belt** which is unveiling a new 45 tonne telescopic

Cross the next aisle to **Kobelco** which has three of its G series fuel efficient cranes on the stand - the 100 tonne CK1100G, 145 tonne



function, including main winch, travelling, slew, holding a load, what percentage of chart the crane lifted, and much more. Also take a look at the company's service training simulators.

Continuing in the same direction brings us to **Tadano** which is launching the 120 tonne **Mantis** GTC1200 its largest heavy duty telescopic crawler crane. We now head over the road to the Silver Lot towards the massive **Sany** stand. But stop on the way and look at mini crawler crane manufacturer **Maeda** that are ideal where space is at a premium. Sany has made substantial progress with its American designed crawler crane range and will have a selection of units on display. Across the aisle is fellow Chinese producer



Maeda LC785

Zoomlion with two crawler cranes on show, the 100 tonne ZCC1100H and the 260 tonne QUY260. Heading further into the Silver Lot and you will find **Sennebogen** which will display two material handling cranes rather than its crawler cranes. Finally if you are interested in **Foundation cranes** you are best to get on a shuttle over to the remote Platinum Lot.



Tadano Mantis GTC-700EX

Conexpo suele ser un excelente espectáculo para el lanzamiento de grúas sobre orugas y las innovaciones, y este año no es una excepción, con mucho que ver y varios nuevos productos emocionantes. La mayoría de los todos los lanzamientos de nuevos modelos son telescópicos, pero también es probable que se sorprenda con algunos nuevos modelos convencionales.



Maeda

Comenzamos nuestro recorrido en el Gold Lot en el stand de **Liebherr** en donde usted puede encontrar la mayor grúa sobre orugas en Las Vegas, una LR11000 de 1.100 toneladas. Fue presentada hace dos años, y estará disponible ahora con el sistema Boom de energía de la compañía para aumentar las capacidades. Es una enorme grúa que ha sido diseñada para ser lo suficientemente compacta como para su uso en zonas estrechas. Liebherr mostrará también la LR 250 de 1250 t, con su anchura de transporte tres metros y una amplia variedad de opciones para satisfacer una multitud de aplicaciones.

Ahora diríjase pasado JCB hacia Vertikal y encontrará el fabricante de grúas chino **XCMG**, en el momento

de entrar en imprenta no estábamos seguros qué esperar, la compañía ha estado trabajando duro en el extremo de gama superior del mercado de grúa sobre orugas, pero se ha hecho poco fuera de China. Ahora corte detrás de JCB hacia **Terex** donde se encuentra su Superlift 3800 de 650 t, sucesora de la serie CC2800. Se dio a conocer hace un año y medio, esta es la primera oportunidad de ver la nueva grúa en América del Norte. Ahora nos dirigimos a **Link Belt** que está presentando una nueva telescópica sobre orugas de 45 toneladas, la TCC500, una gama con tres modelos. Apuntando al mercado de servicios, esta nueva grúa tiene una pluma 33,5 metros de cuatro secciones.

Ahora cruzamos el pasillo para **Manitowoc** que ha prometido dar a conocer una "nueva e interesante gama de grandes grúas sobre orugas con pluma de celosía" en la feria. Sabemos que la nueva MLC165 de 165 toneladas hará su



Link-Belt TCC500

debut en los EE.UU. y que estará acompañado por dos grúa sobre orugas completamente nuevas, pero eso es todo lo que sabemos, por lo que definitivamente vale la pena una parada. La MLC165 lanzada el año pasado en Bauma es una grúa "global" diseñada para ser fácil de transportar, totalmente auto-montable. La longitud máxima del brazo es de 84 metros y con plumines fijos o angulación variable



Manitowoc MLC165

opcional, la longitud máxima del sistema es de 102,8 metros.

Cruce el pasillo siguiente hacia **Kobelco**, que tiene tres de sus grúas de la Serie Eficiente de combustible G en el stand, la CK1100G de 100 toneladas, CK1600G de 145 toneladas y CK2750G de 250 toneladas - la nomenclatura refleja las capacidades máximas de toneladas de Estados Unidos. Además, la compañía dará a conocer su Sistema KCross - estándar en la serie G, que permite el monitoreo satelital remoto de la unidad desde el escritorio del usuario. El sistema se dice que es fácil de usar y proporciona informes diarios, semanales y mensuales.

Continuando en la misma dirección está **Tadano** y su línea de grúas sobre orugas Mantis telescópicas de alta resistencia. De regreso por el mismo camino, encontrará **Link Belt** que está centrando su lanzamiento de nuevos productos en las grúas telescópicas. Ahora nos dirigimos por el Silver Lot hacia el masivo stand de **Sany**. Pero aproveche el camino y mire la gama de mini grúas sobre orugas de **Maeda**, ideales cuando el espacio es un bien escaso. **Sany** ha hecho progresos



XCMG QUY800

sustanciales, con su gama de grúas sobre orugas de diseño americano y tendrá una selección de unidades en pantalla. Al otro lado del pasillo estará el compañero productor chino **Zoomlion** con dos grúas sobre orugas en demostración, la ZCC1100H de 100 toneladas y la QUY260 de 260 toneladas. Siga por el Silver Lot y encontrará **Sennebogen** que muestra dos grúas de manipulación de materiales en lugar de sus grúas sobre orugas. Por último, si usted está interesado en **Foundation cranes** (Fundación de grúas), coja un bus que le traslade al Platinum Lot.



Maeda LC785



Tadano Mantis GTC-700EX



Gold Lot - 2115



LIFTING TO A HIGHER STANDARD

One company. Six brands. Turn to Manitex International for any lifting solution, any terrain, any job. Our cranes, rough terrain forklifts, reach stackers, container handling equipment and special mission-oriented vehicles are all backed by the most thorough parts and service support in the business.

BETTER PRODUCT, BETTER PAYBACK.

www.ManitexInternational.com

Manitex International: 2012 & 2013 Forbes List of America's Best Small Companies

Manufacturer • Fabricante	Stand	Lot
Altec	1827	Gold
Atlas	3554	Silver 1
Auto Crane	6710	Silver 4
Cargotec, Hiab	4748	Silver 2
Elliott Equipment	1108	Gold
Fassi	2736	Gold
Furukawa-Unic	3249	Silver 1
Hiab	4748	Silver 2
HMF	10652	North
Iowa Mold Tooling	10652	North
Manitex	2155	Gold
Maxilift	4086	Silver 1
National Crane	2137	Gold
Manitex	2155	Gold
Next Hydraulics	4086	Silver 1
PM	4782	Silver 1
Service Trucks Int	1310	Gold
Stellar Industries	1406	Gold
Tadano	2101	Gold
Terex	1047	Gold



Palfinger PAL Pro



Altec-Lmap

We start with Fassi and distributor Fascan in the Gold Lot. New products include the heavy-duty F950RA.2.28L426 and the improved light-duty, F120B.2.25. Check out the Fassi Stability Control (FSC) system which automatically limits crane operation when pre-set stability conditions are not met.

Cross the aisle to Manitowoc and National Crane with its three NBT15 series models, filling a gap between 9.1 and 16.3 tonnes, all feature an 18.3 metre three section boom.

Cross the Kobelco stand to Manitex which is launching the 19 tonne 1970C with its 21 metre boom, no extra counterweight and two jib

National Crane NBT15 Series



Empezamos el tour con Fassi y su distribuidor Fascan en el Gold Lot. Los nuevos productos incluyen la F950RA.2.28L426 de alta resistencia y la mejora el modelo ligero, F120B.2.25. Eche un vistazo al Fassi Stability Control (FSC) ¿Qué sistema limita automáticamente el funcionamiento de la grúa cuando no se cumplen las condiciones de estabilidad pre- establecidos?

Cruce el pasillo para Manitowoc y National Crane con sus tres modelos de la serie NBT15, llenando el hueco entre sus grúas de 9,1 y 16,3 toneladas, todos cuentan con pluma una de tres secciones de 18,3 metros.

Cruce el stand de Kobelco a Manitex que está lanzando la 1970C de 19 toneladas con su pluma de 21 metros y el contrapeso y dos opciones de pluma extra. Manitex también vende grúas PM articuladas

y están mirando a una cooperación más estrecha. Al otro lado del pasillo tiene a Altec con la AC45-127S de 41 toneladas, pero eche un vistazo a su momento de carga y sistema de protección de la zona (PSM), con su gran pantalla a color. Tadano está justo al final del pasillo, y luego cruzamos a Marooka donde destacan la grúa sobre chasis de orugas. Pase por Terex y vea su mayor camión grúa hasta la fecha. Finalmente nos dirigimos a Elliot Equipment para ver su nuevo modelo 41.452 de 41 toneladas y accesorios para aplicaciones especializadas más pequeñas. Allí encuentra también a Stellar Industries y Service Trucks con su nueva grúa 7543 Tiger.

Cruce la calle para el Salón Norte y está IMT que distribuye HMF, que tendrá las grúas de gama media en la demostración, basada en la serie HMF 910K con momento de carga

options. Manitex also sells PM cranes and us looking at closer co-operation. Across the aisle Altec has the 41 tonne AC45-127S, but check out its Load Moment and Area Protection System (LMAP) with its colour screen. Tadano is just down the aisle, and then cross the Marooka stand, checking the cranes on tracked chassis, before reaching Terex and its largest boom truck to date. Finally we head for the exit and Elliot Equipment to see its new 41 tonne 41452 and smaller cranes and attachments for specialist applications. If you are into service-body cranes Stellar Industries and Service Trucks - with its new 7543 Tiger crane - are just opposite.

Cross the street to the North Hall and IMT which distributes HMF. It has its mid-range articulated cranes on show, based on the HMF 910K series with load moments of nine to 12 tonne/metres. It has also

upgraded its electric telescopic cranes for pick-up trucks topped by the 2,700kg capacity 6000.

Out in the Silver Lot Palfinger has its largest knuckle boom the 200 tonne/metres PK200002 L SH mounted on a Western Star truck. Its nine section boom and eight section jib gives a tip height of 50 metres. Check the PAL Pro 72 and the PSC 6229 service crane. Next door Spydercrane can update on Furukawa Unic telescopic cranes. Behind the Zoomlion stand is Atlas with infamous owner Fil Filipov on hand to discuss his plans, a little further on brings you to the Hiab stand, and then in the same row PM with its new 150 SP compact, model with integrated base that it claims is easier to install and is available with nine hydraulic sections and six jib extensions with 25 degrees above horizontal articulation. We end with Auto Crane in Silver 4.

Fassi F950RA



de 9 a 12 toneladas/metros. Afuera, Silver Lot, Palfinger tiene su grúa más grande, la PK200002 L SH de 200 toneladas/metros montada en un camión Western Star. Su pluma de 9 secciones y plumín de 8, da una altura en punta de 50 metros. Compruebe el PAL Pro 72 y la grúa de servicio PSC 6229. Al lado Spydercrane puede distribuye las grúas Furukawa Unic. Detrás del stand de Zoomlion está Atlas con Fil Filipov como dueño, disponible para discutir sus planes. Un poco más adelante está Hiab, y luego en el mismo pasillo PM, con su nueva grúa 150 SP - modelo compacto, con base integrada que dicen es más fácil de instalar y está disponible con nueve secciones y seis extensiones de plumín hidráulico con 25 grados por encima de la articulación horizontal. Terminamos con Auto Crane en Silver 4.

IMT 6000



Manitex 1970C



Palfinger PK200002



MORE ENERGY

Never change a smart design, but...

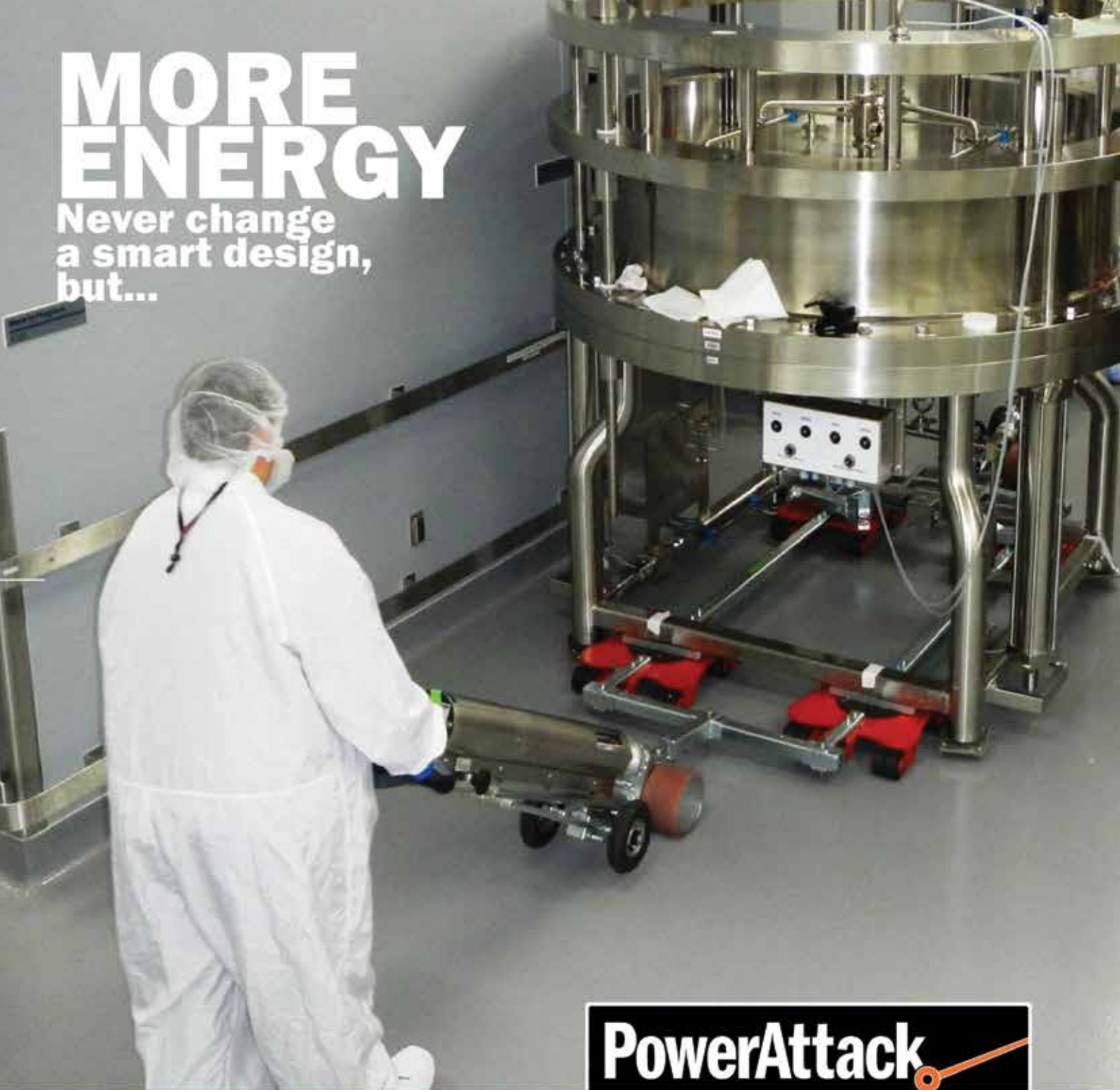

PowerAttack

® Made in Germany

www.PowerAttack.biz

...we have boosted
Torque by 200%
Battery life by 20%

But we kept the compact size and versatility.

PowerAttack - The Load Mover

The innovative idea to move loads on passive, unpowered skates or trolleys instead of a fork-lift truck.



MTC 30 CC Cordless

MTC 25 C Compact



Designed, manufactured and guaranteed by:

Klaus J. Scholpp
PowerAttack GmbH
Nanetteweg 5
D-70839 Gerlingen
Tel. +49 (0) 7156 - 177 33 42
www.powerattack.biz



Manufacturer • Fabricante	Stand	Lot
Comansa	2181	Gold
Comedil - Terex	1047	Gold
Liebherr	2155	Gold
Linden Comansa	2181	Gold
Manitowoc	2137	Gold
Potain	2137	Gold
Terex	1047	Gold
Zoomlion	3554	Silver 1

We start this tour with Potain on the Manitowoc stand which has two units on display including the largest in its self-erecting range, the single trailer transport eight tonne capacity Igo T130.

Features include variable mast heights, remote control and various jib configurations, including an offset jib to avoid obstacles. Maximum radius is 50 metres with a tip capacity of 1,400kg and maximum hook height is 37.2 metres. Also on the stand is the quick set-up Potain MR418 luffing jib tower crane which has a new on-board control system which allows rapid operation.

Next door Liebherr is launching the 542 HC-L 18/36 Litronic luffer. Maximum capacity is 36 tonnes but it is also available in 12/24 or 18/36 tonne versions. The luffing gear has



Liebherr 542 HCL

been improved to suit the lifting capacity, so that shorter adjusting times are possible. Liebherr has improved the jib's out-of-service position, resulting in a reduction of around 2.5 metres. The climbing process has also been improved with a new electronically secured climbing guide section. Sensors on the guide section report the current climbing status to the Litronic crane controller. Specially adjusted climbing curves based on the recorded data can be provided using the Litronic controller to ensure maximum safety.

Continue towards the back of the

Gold Lot for Linden Comansa which is highlighting its PowerLift system



Linden Comansa 21LC660

which it claims gives a 10 percent improvement to the load chart as a result of reduced lift speeds. This system is now fitted as standard on the company's flat-top tower cranes. The LC1100 and LC2100 Series have also been updated and improved.

Now cross the JCB stand to Terex which has not announced any new tower cranes for the show, but will show examples from its flat top, luffer, self-erector and hammer head ranges and may have a surprise. Finally, another we cross the street to the Silver Lot and Zoomlion which has not said what it will have on the stand.

Terex



Comenzamos este recorrido con Potain en el stand de Manitowoc que tiene dos unidades en exposición, la más grande de su gama automontante, la única remolcable de transporte de ocho toneladas de capacidad, Igo T130.

Las características incluyen alturas de columnas variables, control remoto y varias configuraciones de pluma, incluyendo un plumín de desplazamiento para evitar obstáculos. El radio máximo es de 50 metros con una capacidad en

punta de 1.400 kg y la altura máxima de gancho es 37,2 metros. También en el stand estará la Potain MR418 de rápida puesta en marcha que tiene un nuevo sistema de control a bordo que permite un funcionamiento rápido.

Al lado, Liebherr está lanzando la 542 HC-L 18/36 Litronic. La capacidad máxima

es de 36 toneladas, pero también está disponible en versiones 12/24 o 18/36 toneladas. El engranaje de abatimiento se ha mejorado para adaptarse a la capacidad de carga, por lo que los tiempos de ajuste son lo más cortos posible. Liebherr ha mejorado la posición de la pluma fuera de servicio, lo que resulta en una reducción de alrededor de 2,5 metros. El proceso de escalada también se ha mejorado con una nueva sección de guía de escalada electrónica segura. Los

sensores en la sección de guía informan el estado actual escalada al controlador de la grúa Litronic. Las curvas de escalada son especialmente ajustados en función de los datos registrados que se pueden proporcionar utilizando el controlador Litronic para garantizar la máxima seguridad.

Continuar hacia la parte posterior del Gold Lot hacia Linden Comansa que está destacando su nuevo sistema PowerLift que afirma le da una mejora del 10 por ciento a la tabla de carga como consecuencia de la reducción de velocidades de elevación. Este sistema está equipado de serie en las grúas torre flat top de la compañía. La Serie LC1100 y LC2100 también se han actualizado y mejorado.

Ahora cruza JCB hacia Terex que no ha anunciado ninguna nueva grúa torre para la feria, pero mostrarán ejemplos de su gama flat top, plumín de angulación, auto-ercción y

Potain Igo T130



pueden tener una sorpresa. Por último, cruzamos la calle al Silver Lot donde Zoomlion no ha dicho lo que tendrá en el stand.

Performing live in Las Vegas for the first time, - come see the show!

Our new range of Material Handling Equipment will be performing for the first time in Las Vegas - March 4-8, 2014 in booth #2765 in the **Gold Lot** at ConExpo. Tickets on sale now!



Mighty Crane



Compact & strong mini cranes!

- Two models: CR285D / CR335D
- Lifting height - 28' 6" / 41'2"
- Five section full automatic boom
- Easy Hook-In system
- Remote operation controller
- Able to work in narrow or confined- hard to access areas
- Safety moment limiter standard
- 4 falls / 2 falls / 1 fall hook block



Winlet Glass Handler



Compact, lightweight & safe!

- Three models: Winlet 770/ Winlet 1265/ Winlet 1320
- Lifting capacity: 770 lbs - 1265 lbs - 1320 lbs
- Lifts airtight materials
- Able to work in narrow doorways, elevators and balconies
- Twin wheels for tough terrain
- Self propelled
- Easy to transport
- Efficient

**Booth #2765
Gold Lot**



Toll Free: 866-358-7088 www.reachmaster.com

Manufacturer • Fabricante	Stand	Lot
Spider Cranes		
Cormidi	3600	Silver 1
Jekko	1095	Gold
Maeda	3211	Silver 1
Mighty Crane	2765	Gold
R&B Engineering	2765	Gold
Reachmaster	2765	Gold
Spydercrane Sales	3249	Gold
Unic	3249	Silver 1
Pick&Carry Cranes		
Broderson	1324	Gold
Galizia	2765	Gold
Grove	2137	Gold
Jekko	1095	Gold
JMG	2309	Gold
Liebherr	2155	Gold
Shuttlelift	2137	Gold
Terex	1047	Gold
Valla	2115	Gold

Since the last Conexpo the number of spider and pick&carry crane companies operating in North America has mushroomed, so this year we have a dedicated tour.

We begin in the Silver Lot with **Cormidi** and its multi-purpose spider crane/spider lifts. The base machine can be fitted with either a platform or crane with maximum working/

a man basket, new jibs and a remote controlled vacuum glass manipulator. Almost next door Unic distributor **Spydercrane Sales** has a good selection of cranes, ranging from the 995kg capacity URW-094 to the four tonne, 18.2 metre boom URW-547. We now cross the road to the Gold Lot where first stop is carry deck crane manufacturer **Broderson**.



Jekko
SPX1275

lifting heights of between 19 and 22 metres. As a crane it can lift 800kg and in platform mode it has substantial underbridge capability.

Passing Palfinger brings you to **Maeda** and three MC spider cranes and a new auxiliary winch with 100m/330ft rope capacity, for working from upper floors of high buildings.

Options on display include a man basket, new jibs and a remote controlled vacuum glass manipulator. Almost next door Unic distributor **Spydercrane Sales** has a good selection of cranes, ranging from the 995kg capacity URW-094 to the four tonne, 18.2 metre boom URW-547.

We now cross the road to the Gold Lot where first stop is carry deck crane manufacturer **Broderson**.



Unic URW

Under new ownership since September, it will be worth stopping in to find out what new owners - Lanco - has planned. Passing **Terex**, which is not showing its Australian-built Franna cranes, we reach **Jekko**, which builds both spiders and a two tonne pick&carry crane. Check out the new 990kg SPB 209 and 1.2 tonne SPX 312, however the main focus is the new 7.5 tonne SPX 1275, the largest in Jekko's range with a 17.7 metre boom.

Follow the rear perimeter past Vertikal to the rear of Liebherr for **ReachMaster** and the launch of two new lines, Japanese built **R&B/Mighty Cranes** spiders and **Galizia** with its two tonne G-20 pick&carry

crane, ideal for curtain walling. Nearby **Manitowoc** is launching the new 18 tonne **Grove/Shuttlelift** CD5520 carry deck crane with 16.6 metre four-section full-power boom. Then cross Kobelco's stand to **Manitex** which recently acquired Valla battery powered pick&carry cranes, before ending the tour next door at **JMG**, making its US debut with its pick&carry cranes.



Maeda spider cranes



Galizia G20

Comenzamos en el Silver Lot con **Cormidi** y su grúa/plataforma de araña de usos múltiples.

La máquina base puede incorporar una plataforma o grúa con alturas máximas de trabajo y de elevación de entre 19 y 22 metros. Como una grúa puede levantar 800 kg, y en el modo de plataforma tiene una capacidad bajo puente sustancial.

Pasando Palfinger te lleva a las grúas de araña de **Maeda** y un nuevo gancho auxiliar con capacidad de 100m, para trabajar desde los pisos superiores de los edificios altos. Las

opciones incluyen una cesta, nuevos plumines y un manipulador de cristal al vacío con mando a distancia. Casi al lado, el distribuidor de Unic, **Spydercrane Sales**, que está exhibiendo las grúas que van desde la URW-094 de 995kg de capacidad, a la grúa de cuatro toneladas y pluma de 18,2 metros, modelo URW-547.

Ahora cruzamos la calle al Gold Lot y la

primera parada es el fabricante de la grúa de carga **Broderson**. Con nuevo propietario desde septiembre, pare para averiguar lo que los nuevos propietarios - Lanco - han planeado. Pasando **Terex**, que no está mostrando sus grúas Franna australianas, alcanzamos **Jekko**, que se basa tanto en las mini grúas como en la grúa pick&carry de dos toneladas. Eche un vistazo a la SPB 209, de 990 kg y SPX 312, de 1,2 toneladas, sin embargo, el foco principal es la nueva SPX 1275, de 7.5 toneladas, la más grande variedad de Jekko con pluma de 17,7 metros.

Siga el perímetro trasero a la parte trasera de Liebherr y vea **ReachMaster**, con el lanzamiento de dos nuevas líneas - las grúas japonesas **R&B/Mighty Cranes** y la grúa pick&carry G-20 de **Galizia** con sus dos toneladas. Cerca, **Manitowoc** lanza una nueva grúa de 18 toneladas **Grove/Shuttlelift** CD5520 con 16,6 metros de pluma de cuatro secciones. A continuación, cruce el stand de Kobelco a Manitex que recientemente adquirió las grúas pick&carry de **Valla**, antes de terminar la gira al lado en **JMG**, haciendo su debut en EE.UU. con su selección de grúas pick&carry.



JMG MC45



Shuttlelift CD5520

Safety rules for operating AWP's near power lines

By Chris Wraith, IPAF technical officer

Electrocutions were the single largest reported cause of fatalities among US aerial work platform operators in 2012 - with eight reported fatalities. In 2013, a further seven fatalities were the result of electrocution, all of them in the USA and all on boom-type machines (self-propelled booms, bucket trucks or trailer-mounted).



The 15 electrocutions occurred when the operator of the boom inadvertently came too close to or touched overhead cables. These operators were not trained electricians, but were working close to power lines, performing tasks such as maintenance, construction, trimming vegetation, and in one case, attempting to rescue a balloon! While precise details are not known in individual cases, the evidence suggests that the most probable reasons were:

- Apparent lack of awareness of the proximity of the overhead power lines
- Apparent complacency or lack of awareness of the voltage running through the cables
- Moving the boom in the wrong direction when close to overhead cables
- Operating the boom erratically and not stopping when and where expected

Qualified line workers do receive detailed training before working on or near energy installations, so the greater risk is from those who have not had that specific training and just happen to have to work near energized overhead cables.

Where possible, the overhead cables should be de-energized and tagged before work begins. However, this is not often possible as power companies are reluctant to disrupt public supplies. If "de-energizing" is out, consideration should be given to protecting operators and others in the platform, by 'shielding' the cables and using specialist insulated aerial devices which are specifically designed to work near electrical hazards. The use of overhead cable proximity indicators should also be considered when the risk of working near overhead cables is identified.

Emphasis is placed on the Minimum Approach Distance (MAD), the safest distance a person without specific training is permitted to come to live overhead cables.

When operating any platform, it is essential to use the controls to apply smooth, slow and calculated

movements of the boom, ensuring it moves in the desired direction and stops where intended, and you do not exceed the MAD.

Note that you do not need to touch the wires to be in danger, just being close will place you at significant risk. The higher the voltage and the more moist the atmosphere, the further electricity can jump. That is why, when working near overhead cables, the MAD should be clearly marked on the ground, allowing for maximum boom outreach. You should also ensure extra supervision is provided and emergency plans are in place.

Through its training programs, advice and guidance, IPAF endeavors to remove confusion and reduce the risk by training operators and managers on the need for extra measures once any of two specific safe distances are breached. These are:

- 50ft (15m) + fully extended boom from electrical pylon
- 30ft (9m) + fully extended boom from cables on wooden poles

Working from an AWP closer than these distances is allowed, but extra measures must be in place; 30 and 50 feet plus the fully extended

boom are the 'triggers' for extra risk assessments and the need to seek the advice of the electricity supplier or qualified person who can positively identify:

- Which cables carry electricity
- The voltage of the energized cables
- The appropriate MAD
- Any extra measures required before work continues

Aerial lifts are designed to provide a safe means of working at height but they are only a safe option if their use is planned and managed appropriately. Electrocution is one of the leading hazards associated with their use in the USA. Make sure you, and those you are responsible for, apply the "30 and 50ft plus fully extended boom" rule to ensure that you stay safe.

References on this subject include:

US Code of Federal Regulations (CFR) 1910.333

ANSI A92 Standards

ISO 18893 MEWP Safety Principles, Inspection, Maintenance and Operation

IPAF Operators' Safety Guide

Statement of Best Practices for Workplace Risk Assessment and Aerial Work Platform Equipment Selection, available at the Publications section of www.ipaf.org

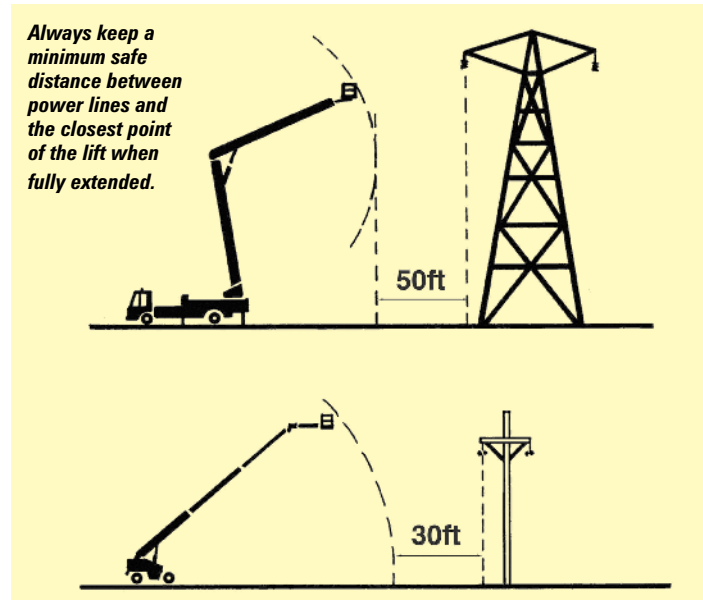

Visit IPAF at the Lift Safety Zone in the Gold Lot #1817 to view live demos that raise awareness of electrocution risks when operating near power lines.

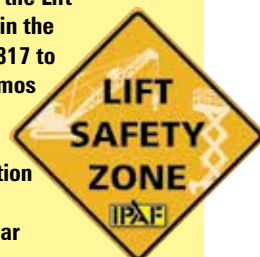

Normas de seguridad para usar PTAs cerca de líneas de tensión

Por Chris Wraith, delegado técnico de IPAF

La electrocución fue la causa más numerosa de muerte de operadores de plataformas de trabajo aéreas (PTAs) en 2012 en EEUU, según la base de datos de accidentes de IPAF. En 2013, 7 (13%) de 53 accidentes mortales fueron producidos por electrocución, tras un vuelco (16), caída desde altura (13) y atrapamiento (10). Los 7 casos de electrocución ocurrieron en EEUU, país que concentra el 54% de la flota de alquiler de todo el mundo, donde se informó de un total de 30 muertes. Las muertes provocadas por electrocución estaban relacionadas y ocurrieron principalmente con máquinas de brazo: 4 ocurrieron con plataformas de brazo móviles (3b) y 3 con plataformas de brazo estáticas (1b).



Las electrocuciones con una PEMP/PTA de las que se informó ocurrieron cuando el operador o el brazo de una PEMP/PTA se acercó demasiado de forma inconsciente a los cables aéreos o los tocó. Estos operadores no eran electricistas formados, pero estaban cerca de líneas eléctricas realizando tareas de mantenimiento o construcción, podando vegetación o, en uno de los casos, tratando de recuperar un globo!

Mientras desconozcamos los detalles de cada caso en concreto, las pruebas indican que los motivos más probables fueron:

- Aparente desconocimiento de la proximidad de las líneas eléctricas elevadas
- Aparente falta de seguridad o desconocimiento de la tensión de los cables
- Mover el brazo en la dirección equivocada cuando se está próximo a las líneas elevadas
- Operar el brazo de forma errática y no detenerse en el lugar y momento en que se debería

Los "trabajadores de líneas eléctricas" cualificados reciben formación detallada antes de trabajar en instalaciones de energía o cerca de ellas. El mayor riesgo lo suponen otros trabajadores que no han recibido esa formación específica y de forma puntual trabajan cerca de cables con tensiones e intensidades elevadas.

Siempre que sea posible, se debe cortar la corriente de los cables elevados y etiquetarlos antes de trabajar cerca de ellos. Sin embargo, a menudo no es posible, ya que las compañías eléctricas son reacias a cortar el suministro público. Si cortar la corriente no es una opción, debe considerarse proteger a los operarios y otros trabajadores en la plataforma "apantallando" los cables y usando dispositivos de aislamiento eléctricos (IAD) específicamente diseñados para trabajar cerca de riesgos de tipo eléctrico. Considere el uso de indicadores de proximidad de cables elevados cuando exista el riesgo de trabajar cerca de cables elevados.

Se debe de hacer hincapié en que la distancia mínima de aproximación es la distancia más segura a la que a una persona (cualquiera que no haya recibido la formación específica para evitar riesgos eléctricos) se le permite acercarse a cables elevados con corriente.

Al operar cualquier PEMP/PTA es imprescindible en todo momento

usar los mandos proporcionales para realizar movimientos suaves, lentos y calculados del brazo, asegurándose de que se mueve en la dirección deseada y se detiene donde debe, y no se invade la distancia mínima de aproximación. Tenga en cuenta que no es necesario tocar los cables para estar en peligro, simplemente estar cerca supone un riesgo para usted. Cuanto mayor es la tensión y más humedad ambiental haya, más lejos puede alcanzar la electricidad. Por eso, cuando se trabaje cerca de cables elevados, la distancia mínima de aproximación debería estar marcada claramente en el suelo, permitiendo el mayor alcance del brazo. También debería asegurarse de que exista una supervisión adicional y de que los planes de emergencia estén en su sitio.

Con sus programas de formación, IPAF trata de eliminar la confusión y reducir el riesgo formando a operarios y supervisores en la necesidad de tomar medidas adicionales una vez que se supera cualquiera de las dos distancias de seguridad. Estas son:

- 15 m + plataforma aérea de brazo en completa extensión a partir de la torre de tensión eléctrica
 - 9 m + plataforma aérea de brazo en completa extensión a partir de los cables en postes de madera
- Trabajar desde una PEMP/PTA más cerca de las líneas eléctricas que estas distancias está permitido, pero deben tomarse medidas adicionales; 9 y 15 metros más el brazo extendido son los

"desencadenantes" de evaluaciones de riesgo adicionales y la necesidad de buscar consejo del proveedor de energía eléctrica o una persona "cualificada" que pueda identificar sin duda:

- Qué cables conducen electricidad
- Voltaje de los cables con corriente
- Distancia mínima de aproximación adecuada
- Cualquier medida adicional necesaria antes de continuar con el trabajo

Las PTAs están diseñadas para proporcionar acceso para un trabajo temporal en alturas, pero sólo son una opción segura si su utilización se planifica y gestiona adecuadamente. La electrocución es uno de los principales riesgos fatales asociados al uso de PTAs en EEUU. Asegúrese de que usted y aquellos de los que es responsable, apliquen la regla de "9 y 15 metros más el brazo extendido" para garantizar su seguridad.

Las referencias sobre este tema incluyen:

El Código de regulaciones federales de EEUU (CFR) n° 1910.333

Normas ANSI A92

ISO 18893 - Principio de seguridad, inspección, mantenimiento y funcionamiento de PEMP/PTA

Guía IPAF de seguridad del operador

Guía de buenas prácticas para evaluación de riesgos en el lugar de trabajo y selección de equipo de plataformas aéreas, disponible en la sección "Publicaciones" de www.ipaf.org

Visite IPAF en "Lift Safety Zone" en el número 1817 de Gold Lot para presenciar demostraciones en directo que conciencian de los riesgos de electrocución al operar PTAs cerca de cables eléctricos.



Mantenga siempre una distancia mínima de seguridad entre las líneas eléctricas elevadas y el punto más cercano a ellas de la PTA en su posición completamente extendida.

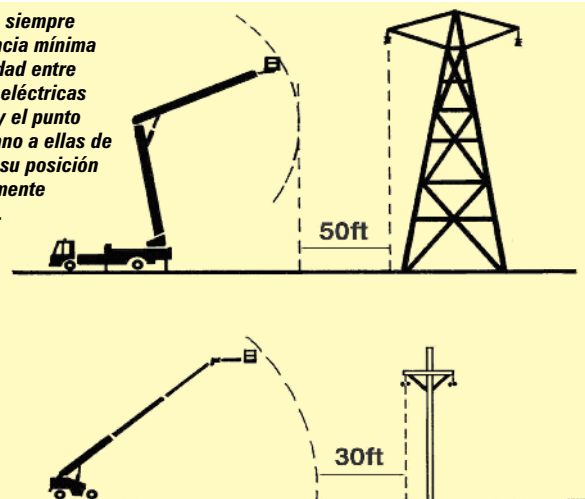



WHO YOU CALLIN' SMALL?

Hy-Brid low-level scissor lifts might be compact, but they deliver in huge ways. Light weight, yet high capacity. Ample platform space, yet small enough to maneuver into elevators and through doorways. Low stowed heights, yet 20-foot working heights. All resulting in versatility that's needed from start to finish on every job.

Hy-Brid Lifts

1-866-334-0756 | WWW.HYBRIDLIFTS.COM



Manufacturer • Fabricante	Stand	Lot
Bil-Jax	1531	Gold
Dingli	6445	Silver 4
Haulotte	1531	Gold
Genie	1047	Gold
JLG	1037	Gold
Manitou	12605	North
MEC	6148	Silver 4
Niftylift	4118	Silver 1
PB Lifetechnik	2765	Gold
Skyjack	1837	Gold
Snorkel	4218	Silver 1
Tadano	2101	Gold

We begin our tour on the Terex stand with Genie and its 180ft SX 180. Shown last year at Bauma the first units are now shipping, following nine months of testing, which has resulted in changes to the unique jib rotation which is now 60 degrees (30°+30°).

Also take a look at the secondary guarding system taken from Blue Sky and its new telematics hook up. You might also ask the company about its plans for an all new 33ft/12m lightweight articulated boom.

Cross the aisle for the major product launch of the show, JLG's record breaking 185ft JLG1850SJ. The all new machine includes an X-type chassis, five section boom and two section articulating jib. Platform capacity is 450kg/1,000lbs, outreach around 25 metres, overall weight 27 tonnes and it does not require an oversize permit for transport. Another ground breaking new product is the company's first

hybrid boom lift. The H340AJ has AC direct electric drive, with four fully sealed brushless AC electric wheel motors, powered by a maintenance-free battery pack and a small diesel engine with generator and regenerative charging.

Cross the aisle to Haulotte which is highlighting its 23m/67ft HT23RTJ/HT67RTJ which is now being delivered on both sides of the Atlantic. The unit offers high lift speeds, 18 metres outreach and 450kg platform capacity. Also ask about the company's Activ'Shield Bar secondary guarding system. Other lifts on show include the HA41PX-NT its largest articulated boom lift, the popular Star 10 mast boom and 18m/55ft Bil-Jax 55XA self-drive boom lift. Cross the aisle to Skyjack which has not indicated that it has a new boom for the show, but is expected to make a new



Genie SX-180

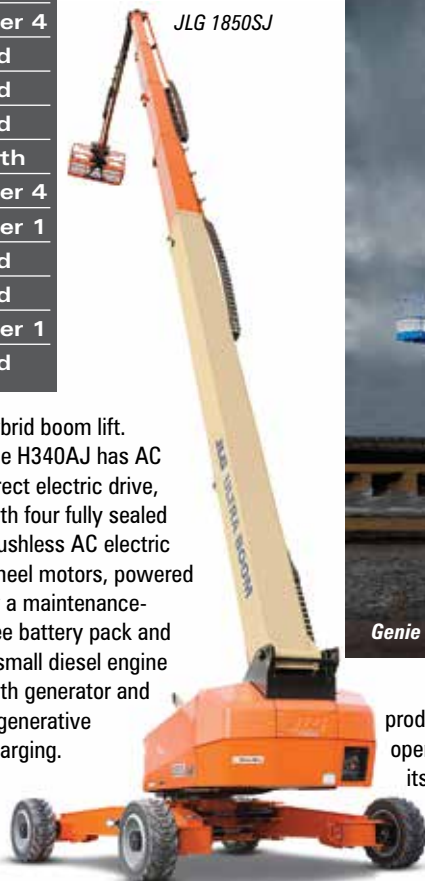

JLG 1850SJ

product announcement on the opening day. It will also show its other units with upgraded power packs as well as its two secondary guarding solutions on display. We now head over the road,

past the North Hall and Manitou - which does not sell its access products in the USA - to the Silver Lot and Niftylift, which probably has the highest concentration of boom lifts at the show. Check out its hybrid models, its Tough Cage and SiOPs - secondary guarding system - the original solution to crushing incidents in boom lifts. Its 45ft boom is also around two tonnes lighter than most and therefore easier to transport. Across the aisle Snorkel and new owner Don Ahern is promising to have new models ready, likely to include simpler, back-to-basics versions of

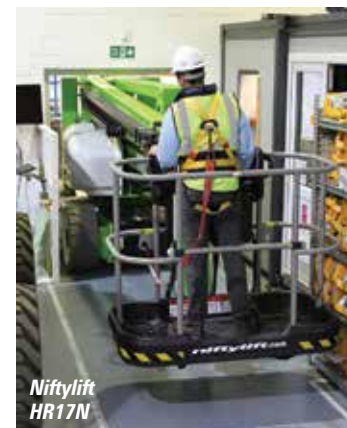

Niftylift HR17N

the current Snorkel models. Finally keep going to Silver Lot 4 to see Chinese manufacturer Dingli making its Conexpo debut. The company produces a wide range of booms and recently launched an 11m/36ft mast boom. Nearby MEC is showing off its 60ft Titan boom - which for most visitors will be the first opportunity to give it a look over - but it is more a scissor lift platform on a stick, than a regular boom lift.



Dingli



Snorkel A38E



Skyjack SJ51AJ



Simply Reliable

By keeping design simple and using proven technology, Skyjack products offer the rental industry's best life cycle value through low cost of ownership, ease of service and maintenance while retaining high residual values.

Skyjack products feature:

- Standard color coded and hard wired relay based control systems which are easy to trouble shoot and repair using commonly available components
- Common components across model groups making replacing or repairing components easy and cost effective
- Replaceable modular platform railings and repairable fiberglass cowlings.
- No complicated and expensive computers or can-bus systems
- Robust steel construction

For information call 1-800-265-2738 or visit us online at www.skyjack.com



VISIT US AT BOOTH
1837
GOLD LOT

SKYJACK
simply reliable

Vertical Mast Lifts • **Electric Scissor Lifts** • Rough Terrain Scissors • **Articulating Booms** • Telescopic Booms • **Telehandlers**

Manufacturer • Fabricante	Stand	Lot
Bil-Jax	1531	Gold
Dingli	6445	Silver 4
Haulotte	1531	Gold
Genie	1047	Gold
JLG	1037	Gold
Manitou	12605	North
MEC	6148	Silver 4
Niftylift	4118	Silver 1
PB Liftechnik	2765	Gold
Skyjack	1837	Gold
Snorkel	4218	Silver 1
Tadano	2101	Gold

Comenzamos nuestro recorrido en el stand de Terex con Genie y su SX 180 de 180 ft, lanzado el año pasado en Bauma.

Las primeras unidades ya se están enviando, tras nueve meses de pruebas, los cambios significativos se han hecho en el área del plumín, pero la mayoría de los cambios han sido menores. Cruce el pasillo para el mayor lanzamiento de producto de la feria, la plataforma de 185 ft de JLG, que supone un record en altura, la 1850SJ. El nuevo equipo incluye un chasis de tipo X, boom de cinco secciones y plumín articulado de dos secciones. La capacidad de la plataforma es 450kg, alcance de unos 25 metros, peso total de 27 toneladas y se puede transportar con sólo un permiso de peso. Otro innovador nuevo producto es el primer híbrido de elevación de brazo



JLG H340AJ

de la compañía, el H340AJ con motor eléctrico AC 4x4, alimentado por una batería o un pequeño motor diesel y el generador y la carga regenerativa. También mire hacia fuera para su última plataforma de mástil.

Cruza el pasillo para **Haulotte** que está destacando su HT23RTJ de 67 ft o HT67RTJ. La unidad ofrece grandes velocidades de elevación, 18 metros de alcance y capacidad de la plataforma de 450 kg. También

pregunte sobre su barra Activ'Shield de vigilancia secundaria de la empresa. Otras plataformas en la feria incluyen su brazo articulado más grande, la HA41PX -NT y la popular estrella de 10 y 55 pies de **Bil-Jax**, 55XA. Cruce el pasillo de nuevo para **Skyjack** que no ha indicado una nueva plataforma,



Skyjack 45T-2

pero ha estado trabajando en la mejora de sus motores. Ahora nos dirigimos por la carretera pasado el Salón Norte y encontramos **Manitou** que no vende sus plataformas en América del Norte. En el Silver Lot, Niftylift tendrá el stand con mayor concentración de plataformas en la feria. Echa un vistazo a sus modelos híbridos, con cesta resistente y SIOPS - el sistema de protección secundario. Al otro lado del pasillo **Snorkel** con su nuevo propietario, Don Ahern, prometen nuevos modelos, probablemente incluirán versiones más simples de los modelos actuales. Finalmente siga hacia Silver 4 para encontrar al fabricante chino **Dingli**, que produce una amplia gama, y recientemente lanzó una plataforma de mástil. Cerca **MEC** tiene su brazo Titán - más un elevador de tijera.



Niftylift HR15 4x4



Haulotte HT23RTJ



NEW 6092RT!

The Largest Scissor Made In North America

**DEALER
FINANCING
AVAILABLE**



**Come See Us At
ConExpo Booth #6148**



SPEED LEVEL™



CROSSOVER ERT



4069 SERIES



Manufacturer • Fabricante	Stand	Lot
Custom Equipment	1725	Gold
Dingli	6445	Silver 4
Genie	1047	Gold
Haulotte	1531	Gold
JLG	1037	Gold
Manitou	12605	North
MEC	6148	Silver 4
PB Liftechnik	2765	Gold
Skyjack	1837	Gold
Snorkel	4218	Silver 1



Skyjack SJ6826RT

We begin our tour with Genie on the Terex stand and its new 'Hybrid' Bi-Energy compact Rough Terrain range of three models, - the GS-2669, GS-3369 and 40ft GS-4069, with 10, 12 and 14 metre working heights.

The units feature an on-board integrated generator to charge the batteries and supply power to platform and chassis. Cross the aisle to JLG and its simpler, less expensive RS slab electric models, including the 32ft top of the range 3248RS with its 11.5 metre work height on a 1.2 metre wide chassis, check out its multifunction digital indicator. Also check the 20ft 20MVL driveable vertical mast lift for industrial/retail environments, with

an eight metre working height. Crossing the other aisle we find Haulotte and its locally built slab electric scissor lifts, including the Optimum 1930E/8 and Compact 3947E/14 which offers a working height of 46ft/14 metres on a chassis just 47inch/1.2 metres wide. Next door Custom Equipment has its 14ft Hy-Brid HB-1430 compact low-level scissor lift with a working height of over six metres and yet weighs less than a tonne, with a 304kg platform capacity and a roll-out deck extension. Backtracking slightly we come to Skyjack, also launching a compact battery electric 11 metre working height Rough Terrain model - the 32ft SJ6832RTE, on the same chassis as its existing diesel/IC model. You



Genie 20MVL

now need to head past Liebherr to Reachmaster to see something new and different, the PB Liftechnik scissors from Germany.

We now cross the road to Silver 1 and Snorkel, with new owner Xtreme/Ahern - it is not promising any radical new lifts, but is focusing on its come back. Moving on to Silver 4 brings you to Chinese market leader Dingli with units from its extensive compact slab electric scissor lift range including the 46ft 4647 which offers 16 metres working height on a 1.2 wide chassis. Our tour ends on the MEC stand for the launch of its all new 60ft electric Rough Terrain scissor lift, the largest built in the USA with a working height of 20 metres. Don't miss the big Titan - a scissor on a boom.



HyBrid HB1430

Comenzamos nuestro recorrido con Genie en el stand de Terex y su nueva gama todo terreno compacta 'híbrida' Bi-Energía de tres modelos, el GS-2669, GS-3369 y la GS-4069 con 10, 12 y 14 metros de trabajo en altura.

Las unidades cuentan con un generador integrado a bordo para cargar las baterías y el suministro de energía a la plataforma y el chasis. Cruce el pasillo para JLG y sus más simples y menos costosos modelos eléctricos RS, incluyendo el modelo superior de 32 pies, la 3248RS con su altura de trabajo de 11,5 metros en un chasis de 1,2 metros de ancho, eche un vistazo a su indicador digital multifunción. También puede ver el mástil vertical 20MVL para entornos industriales, con una altura de trabajo de ocho metros.

Cruzando al otro pasillo encontramos Haulotte y sus plataformas de tijera eléctricas construidas localmente, incluyendo la Optimum 1930E y Compact 3947E, que ofrece una altura de trabajo de 14 metros sobre un chasis de sólo 1.2 metros de

ancho. Al lado Custom Equipment tiene su tijera compacta de bajo nivel Hy-Brid HB -1430 con una altura de trabajo de más de seis metros y todavía pesa menos de una tonelada, con una capacidad de plataforma de 304kg y una extensión de cesta desplegable. Retrocediendo un poco llegamos a Skyjack, también con el lanzamiento de una tijera compacta eléctrica de batería de 11 metros de altura de trabajo, es un modelo todo terreno - la SJ6832RTE de 32 pies, en el mismo chasis que el modelo diesel/IC existente. Ahora tiene que pasar Liebherr hacia Reachmaster para ver algo nuevo y diferente, las tijeras PB Liftechnik de Alemania.

Ahora cruzamos Silver 1 y encontramos Snorkel, con su nuevo propietario Xtreme/Ahern - no promete ningún elevador nuevo, pero se está centrando en su vuelta. Pasando a Silver 4 llega al líder en el mercado chino Dingli con unidades de su amplia gama de tijeras compactas eléctricas - incluyendo la 4647 que ofrece 16 metros de altura de trabajo en un amplio chasis



Genie GS-4069 BE Hybrid

1.2. El tour termina en MEC con el lanzamiento de su nueva tijera eléctrica todo terreno de 60 pies, el más grande construido en los EE.UU., con una altura de trabajo de 20 metros y no se pierda el gran Titán - una tijera en un boom.



Compact 14 Haulotte

No gambling needed here, - ReachMaster is always a winner!



SEE WHY AT BOOTH #2765 IN THE GOLD LOT AT CONEXPO, LAS VEGAS MARCH 4-8, 2014

Falcon FS105Z

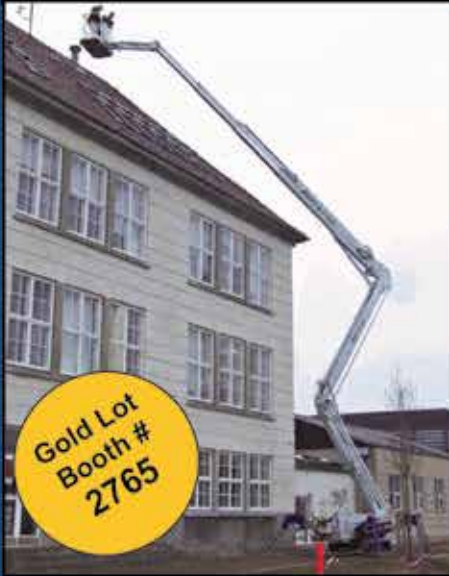

Gold Lot
Booth #
2765

95 - 170 ft work height

- Single door access
- Wheels or tracks
- Double jib
- Dual power (battery + gas or diesel)

39 - 72 ft work height

- Single door access
- Non marking tracks
- Auto—setting
- Dual power (battery + gas or diesel)

BlueLift B72 Combo



Gold Lot
Booth #
2765

PB 74-48



49 - 74 ft work height

- 4 ft wide models
- 4 X 4 models
- All battery power
- Set -up on slopes
- Auto leveling

Gold Lot
Booth #
2765

72 - 92 ft work height

- Single door access
- Extreme light weight
- Battery power
- User friendly

Denka DL92N



DENKA Lifts are back in the US after a 2 year hiatus.

- New owners
- Now build in Germany
- Full service and spare parts support

Our lifts will get you in places no other lift can!

Toll Free: 866-358-7088
www.reachmaster.com



Manufacturer • Fabricante	Stand	Lot
Bil-Jax	1531	Gold
Blue Lift	2765	Gold
Cormidi	3600	Silver 1
Denka	2765	Gold
Genie	1047	Gold
Jekko	1095	Gold
Haulotte	2765	Gold
Hinowa - JLG	1037	Gold
JLG	1037	Gold
Niftylift	4118	Silver 1
Oil&Steel	4782	Silver 1
Omme Lift	2084	Gold
Platform Basket	2084	Gold
ReachMaster	2765	Gold
Snorkel	2765	Gold
TCA Lift	2765	Gold
Teupen	4581	Silver 1
Tracked Lifts	2084	Gold

We start our tour in the Gold Lot on the ReachMaster stand - its largest ever - with a cosmopolitan selection of spider, trailer and atrium lifts, including Italian Blue Lift, German Denka and Danish TCA Lift with its Falcons.

New products include Bluelift's new 18m/59ft B59 spider lift available in three versions including a full lithium battery pack and combo with both lithium batteries and a combustion engine and TCA's revised 32m/105ft Falcon FS105-Z tracked lift with a new remote

control system. This is also the first chance to see the Denka lifts, since new owner Rothlehner restarted production in Germany. Now head towards the Vertikal stand, to find Tracked Lifts and the 27.5m/91ft Omme 2750 RXBDJ Hybrid which can recharge its battery pack via AC or on-board diesel generator. Two Platform Basket spider lifts will be on show, including the 18 metre model, and a new 22m/71ft PB22.10 with 10.3m/34ft outreach and a GVW of 3,000kg. Continuing along the perimeter to Jekko which



JLG



Teupen LEO 21



TCA Falcon

Platform Basket 18.90 PRO



Bil-Jax



Cormidi



Ommelift 2750



Bluelift 18

Comenzamos el recorrido en el Gold Lot en el stand de ReachMaster - el más grande que jamás han tenido - con una selección de plataformas de araña, remolcables y de atrio, incluyendo a las marcas italiana Bluelift, alemana Denka y danesa TCA con sus Falcon.

Los nuevos productos incluyen la nueva araña de Bluelift B59 de 18 m, disponible en tres versiones, incluyendo un paquete de baterías de litio completo y combinado con las dos baterías de litio y un motor de combustión, y la revisada Falcon FS105-Z de TCA de 32 m, con el nuevo sistema de control remoto. Eche un vistazo a los modelos Denka, ahora construidos en Alemania por Rothlehner. En dirección al stand de Vertikal, encontrará la plataforma sobre orugas de Ommelift de 27.5 m, Omme 2750 RXBDJ, una araña híbrida con baterías recargables por AC o a bordo, mediante el generador

diesel. También presenta dos plataformas de araña Platform Basket, incluyendo un modelo de 18 metros disponible en una versión completamente aislada. Continuando a lo largo del perímetro está Jekko que tiene plataforma de araña, la 17C SPL, de 17 m. Próxima parada, Terex, con las plataformas remolcables Genie. Antes cruce a JLG que no sólo construye sus propias plataformas de remolque, sino también vende sus versiones de araña sobre orugas de Hinowa. La compañía está lanzando nuevos modelos X500AJ de 17 m y X600AJ de 20 m como una nueva generación de "rastreadores compactos" de JLG. La próxima parada Haulotte y la gama de Bil-Jax de plataformas remolcables. Si va hacia el Silver Lot encuentra la unidad para usos múltiples con plataforma/grúa/ versión bajo puentes de Cormidi, que monta diferentes plumines con una base común. Cuando el KB22-13 está equipado con una plataforma, el

brazo de cuatro secciones y doble brazo telescópico articulado ofrece una altura de trabajo de 22,5 m y 9 m de alcance (12m con 80 kg). Además, en Niftylift tiene varias remolcables y muchas plataformas. Frente a Snorkel y el nuevo propietario de Xtreme tendrán uno de sus cuatro modelos de elevación remolcables y darán mucho de qué hablar. Activado para Teupen y sus modelos de 2014, donde han renombrando las arañas LEO para América del Norte, con el nuevo LEO 21GT de 21m/69ft convirtiéndose en el TL63A (plataforma de orugas alta articulada de 63 ft)...y finalmente Oil&Steel con su nueva Octopus Evo2300, que tiene 23 m/75 ft.



Oil&Steel Octopus EVO 2300

6000

SKYLIFTS.

120

COUNTRIES.

112

METERS REACH.

50

YEARS OF KNOW-HOW.

1

COMPETENCE: WWW.BRONTO.FI



ABOVE ALL.



Manufacturer • Fabricante	Stand	Lot
Altec	1827	Gold
Condor	3200	Silver 1
Elliott Equipment	1108	Gold
ETI	3311	Silver 1
Hydra	1047	Gold
Manitex	2115	Gold
Oil & Steel	4782	Silver 1
Palfinger	3311	Silver 1
Ruthmann	3200	Silver 1
Tadano	2101	Gold
Terex Utilities	1047	Gold
Teupen	4581	Silver 4
Time	3200	Silver 1
Versalift	3200	Silver 1

This year's show is not particularly strong for truck mounted lifts, with most major European manufacturers not exhibiting.

We begin the tour in the Gold Lot with **Terex Utilities** which builds a wide range of truck mounted lifts including the Hi-Ranger and hybrid powered HyPower units and the **Hydra** under-bridge inspection units, but no units will be on display.

Next head towards the Gold Hall

and **Altec** with a full line-up of aerial lifts for the electric utility, telecommunications, tree care, construction, and lights and signs markets. Its latest model - the 48.6ft AT248F mounted on a 19,500lb GVW chassis - is aimed at the lights and signs sector. Cross the aisle to **Manitex** which will show several units with platform options. Heading towards the exit finds **Elliott Equipment**, with its extensive range of Hi-Reach lifts with heights from

45 to 215ft. Features include full customer customisation creating tailor-made platforms including pressure washers, body and tool box packages etc.

Crossing the road to the Silver Lot and the first stand is **Time Versalift**, which is now the **Ruthmann** dealer for the USA, in addition to a selection of its utility platforms, it will show the 54 metre (175ft) T540/ T175A with 40 metres of outreach on a new four axle chassis - for

easier roading across the USA. Over the aisle **Palfinger** is continuing to establish itself in the North American platform market and is showing its largest truck mounted platform - the 103 metre P1000 truck - as well as the **ETI** articulated telescopic ETC37 IH insulated lift with a 12.7m/42ft working height. Heading towards Silver Lot 4 you will pass **Oil&Steel** on the **PM** stand, so far the company has focused on its spider lifts but it also interested in the truck mounted market. Finally in Silver 4 is **Teupen** but it has no plans to offer truck mounted lifts in North America.



Ruthmann 54



Versalift VST5000

Elliott H110F



La feria de este año no es particularmente fuerte para las plataformas montadas sobre camión, con la mayoría de los principales fabricantes europeos que no exponen.

Comenzamos el recorrido en el Gold Lot con **Terex Utilities** que construye una amplia gama de plataformas montadas sobre camión, incluyendo la gama alta y las unidades híbridas HyPower. También

puede tener una de sus unidades menores de inspección de puentes Hydra.

A vaya hacia el Salón Gold donde **Altec** tiene una línea completa de plataformas aéreas para empresas de electricidad, telecomunicaciones, cuidado de los árboles, construcción, alumbrado y los mercados de señales. Su último modelo - el AT248F, de 48.6 ft montado sobre un chasis de 19.500 libras - está dirigido al sector de la

señalización y alumbrado. Cruce el pasillo para **Manitex** que mostrará varias unidades con opciones de plataforma. En dirección a la salida se halla **Elliott Equipment**, con su amplia gama plataformas de gran alcance, con alturas de 45 a 215 pies. Las características incluyen la personalización completa para el cliente, la creación de plataformas hechas a medida, incluyendo lavado a presión, caja de herramientas, etc

Cruce la calle a Silver y vea **Time Versalift**, que es ahora el distribuidor de **Ruthmann** para los EE.UU., además de una selección de sus plataformas de servicios públicos, se mostrará el T540 / T175A (175ft) con 54 metros de altura de trabajo y 40 metros de alcance sobre un nuevo chasis de cuatro ejes - para todoterreno a través de los EE.UU. A lo largo del pasillo **Palfinger** busca continuar estableciéndose en el sector de la plataforma y expondrá su plataforma más grande, la P1000 sobre camión, de 103 metros - así como la ETI ETC 37 IH aislada, con una altura de trabajo de 42 ft. En dirección al Silver Lot 4 pasará **Oil & Steel**. Hasta el momento la compañía se ha centrado en sus plataformas de araña pero también está interesado en el mercado de plataformas sobre camión. Finalmente en el Silver 4 est **Teupen** pero no tiene planes de ofrecer plataformas sobre camión para América del Norte.

Palfinger ETI ETC37IH



Palfinger WT1000

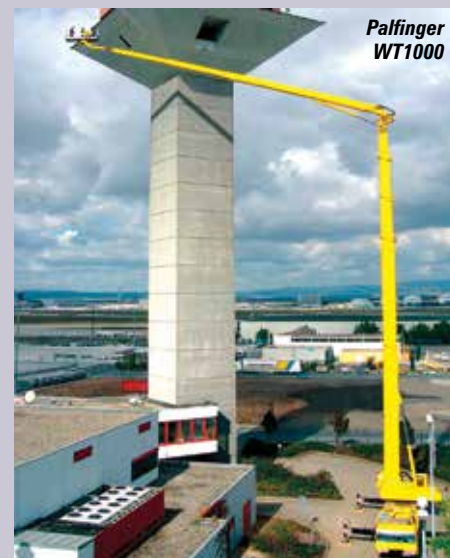



ALPS WIRE ROPE CORPORATION

THE ANSWER TO YOUR LIFTING NEEDS

Call Today! (630) 893-3888



2014 ConExpo Gold Hall - Booth #70043



North American distributor of Hyrope products for KISWIRE LTD.

Subscribe to cranes & access

The only way to guarantee that you receive every issue



HALF PRICE SPECIAL OFFER Two Years for the Price of One

Subscription Application Form

Please complete this form and either fax back on +44 (0) 1295 768223 or +49 (0) 7618 866814 or post to The Vertical Press, PO Box 6998, Brackley, NN13 5WY, UK. Tel: +44 (0)8448 155900

Name _____

Company _____

Job Title _____

Telephone _____

Address _____

Zip/Postcode _____

Country _____

Telefax _____

Email _____

Please start my one year subscription to Cranes & Access at the rate of:

£40.00/€60 (UK and Irish addresses only)

€75.00 (Rest of Europe)

\$110.00 / £60.00 (Other regions)

I enclose a cheque made payable to The Vertical Press

Please invoice me

I enclose an international money order

Please charge to my credit card

Name _____

Card number _____

Expiry date _____

Security code _____

Vertical.net [Subscribe online at www.vertical.net](http://www.vertical.net)

Manufacturer • Fabricante	Stand	Lot
Geda	53090	Central
Hydro Mobile	608	Hotel
Raxtar	608	Hotel
STROS	3476	Silver 1

While there are only a few mastclimber and hoist manufacturers attending this year's show, with those that are spread over quite a wide area.

We will begin the tour in the Silver Lot where you will find **Stros** from the Czech Republic which is showing a prototype machine, the NOV 4561 UP F9W construction hoist. The counterweighted unit has a capacity of 4,500kg/10,000lbs, a car length of 6.1 metres and a maximum lift speed of 90 metres a minute. This is its largest construction hoist the company has made to date. Also check out its HS-1500-F4 industrial elevator.

We now head into the Central Hall where you will find Geda which has a variety of products on show. These include the Geda TP 1100 C and **Geda TP 4400** transport platforms, Geda Ladder Lift, Geda Maxi rope hoist and the PH 2737 650 Single - a

Aunque sólo hay unos pocos fabricantes de plataformas sobre mástil y montacargas que asisten a la feria de este año, las que lo hacen tienen un área bastante amplio, así que se trata de caminar un montón.

Comenzaremos el recorrido en el Silver Lot, donde encontrará **Stros** de la República Checa que está mostrando un prototipo de máquina, el NOV 4561 UP F9W, un montacargas de construcción. La unidad de contrapeso tiene una capacidad de 4.500 kg/10,000 libras, una distancia de un auto de 6,1 metros y una velocidad máxima de elevación de 90 metros por minuto. Esta es su mayor lanzamiento que la empresa ha realizado hasta la fecha. También puede ver el ascensor industrial HS-1500-F4.

personnel and material hoist with a load capacity of 2,700kg or 28 people and a lifting height of up to 400 metres. The highlight of the stand is the new Geda Multilift P22 - a personnel and material hoist with a load capacity of 2,000kg or 22 people and a maximum lifting height of 200 metres.

Next stop is into the Las Vegas Hotel exhibit hall, to see Canadian mastclimber manufacturer **Hydro Mobile** and **Raxtar** hoists which it distributes in North America. Hydro-Mobile has been designing and manufacturing heavy duty North American type mastclimbers for more than 20 years and has more than 5,000 platforms in operation. After a tough time during the

Ahora nos adentramos en el Hall Central, donde encontrará **Geda**, que tiene una variedad de productos expuestos. Estos incluyen las plataformas de transporte Geda TP 1100 C y Geda TP 4400, Geda Escalera Ascensor, Geda Maxi cable de elevación y la PH 2737 650 Individual - un montacargas personal de material con una capacidad de carga de 2.700 kg o 28 personas y una altura de elevación de hasta a 400 metros. Lo más destacado del stand es el nuevo P22 Geda Multilift - un elevador de personal y material con una capacidad de carga de 2.000 kg o 22 personas y una altura de elevación máxima de 200 metros.

La siguiente parada es en Las Vegas Hotel Exhibit Hall, para ver fabricantes de plataformas sobre mástil canadiense **Hydro Mobile**

recession, which hit both Canadian producers hard, it is bouncing back and claims to be the current market leader. Its latest accessory is the Swivel bridge which allows the platform to rotate at various angles up to 180 degrees to cope with access around the corners of buildings and even with irregular angles. It can be used on its M, P, F and E series mastclimbers. While on the stand check out the Raxtar hoists, based in the Netherlands - it produces a range of passenger and material hoists and lifts featuring its Flex-Drive reducing wear on items such as racks, pinions ties and electronic devices.



Stros

y polipastos **Raxtar** que distribuye en América del Norte. Hydro-Mobile diseña y fabrica plataformas de mástil de alta resistencia en América del Norte durante más de 20 años y cuenta con más de 5.000 plataformas en operación, después de un momento difícil durante la recesión que afectó tanto a los productores canadienses, se está recuperando y afirma ser el actual líder del mercado. Su último accesorio es el puente giratorio

que permite que la plataforma pueda girar en varios ángulos de hasta 180 grados, para hacer frente al acceso alrededor de las esquinas de los edificios e incluso con ángulos irregulares. Se puede utilizar en sus plataformas M, P, F y de la serie E. Mientras



Hydro Mobile



Geda Multilift



Hydro-Mobile M Series MU 24

Geda PH 2032 650 Single



que en el stand puede ver los polipastos Raxtar, con sede en los Países Bajos - que produce una gama de montacargas de pasajeros y materiales y ascensores que ofrecen su reduciendo el desgaste de los artículos tales como bastidores, piñones y dispositivos Flex-Drive.



Raxtar



Stros

START THE REVOLUTION

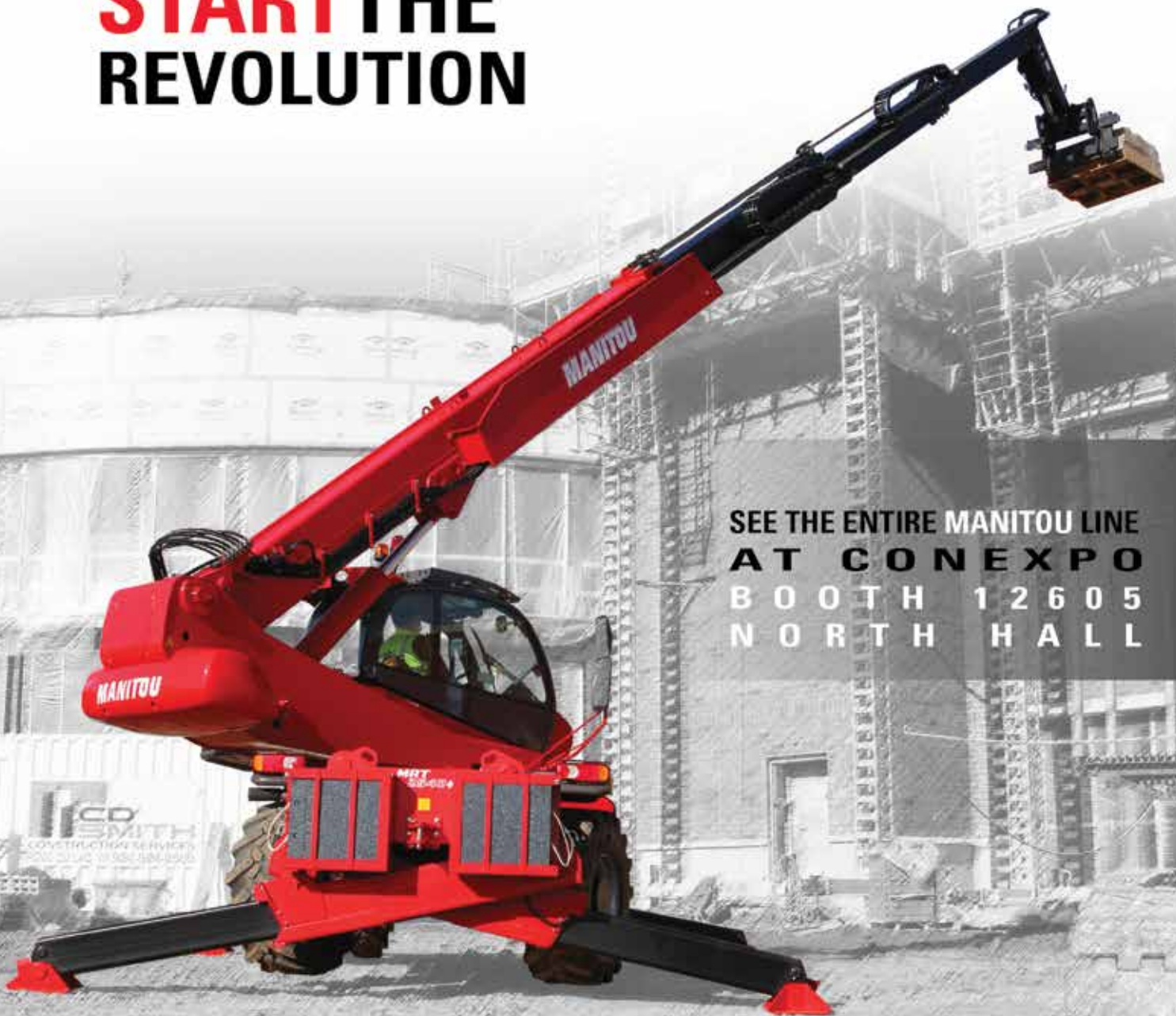

SEE THE ENTIRE MANITOU LINE
AT CONEXPO
BOOTH 12605
NORTH HALL

START A REVOLUTION ON YOUR JOBSITE WITH THE MRT SERIES PRIVILEGE PLUS ROTATING TELESCOPIC HANDLERS.

The unique design of the MRT Series Privilege Plus Telescopic Handlers from Manitou provide rough terrain performance and 360° rotation. Whether your operation needs lifting, crane, or work platform capability the MRT from Manitou is the answer. And with lift heights up to 80'8", this unit gets the job done.



 **MANITOU**

Find your local dealer at manitou.com

Manufacturer • Fabricante	Stand	Lot
Ausa	6736	Silver
Bobcat	1501	Gold
Case	11722	North
Caterpillar	1005	Gold
Dieci	2175	Gold
Doosan	1501	Gold
Gehl	12605	North
Genie	1047	Gold
Haulotte	1531	Gold
JCB	1559	Gold
JLG	1037	Gold
Liebherr	2155	Gold
Lull	1037	Gold
Magni	2115	Gold
Manitou	12605	North
Merlo	4200	silver 2
Mustang	12605	North
Pettibone	3149	Silver 1
Sellick	1071	Gold
Sennebogen	4264	Silver 1
Skyjack	1837	Gold
SkyTrak	1037	Gold
Snorkel	4224	Silver 2
Terex	1047	Gold
Wacker Neuson	4452	silver 2
Xtreme	4224	silver 2



Genie GTH-1544



Caterpillar TH255C

There are plenty of telehandlers at this year's show with most manufacturer's represented.

We begin the tour with Italian manufacturer **Dieci** which is likely to show new models, but is still trying to gain a foothold in the market. Next door **Liebherr** has yet to launch its telehandlers in the USA, however across the aisle **JCB** is unveiling a new six metre/2.5 tonne compact telehandler, the 525-60 Hi-Viz with

side mounted engine and low boom pivot point for improved visibility. It replaces the aging 524-50, 527-55 and the 520-50 rear-engined models. We now head to Terex where **Genie** has three telehandlers on show, including the 15,000lbs/6.8 tonne Heavy Duty GTH-1544 launched last year.



JLG 3614RS

Across the aisle brings you to **JLG**, **Lull** and **SkyTrak**. The JLG display includes two new 'Rental Spec'

machines - the JLG 3614RS and the 4017RS - which are said to offer lower cost of ownership and be easier to maintain. The biggest introduction though can be found on the SkyTrak 10054 and 8042 units, with substantial design improvements - without losing their 'American telehandler' credentials - including single joystick operation, redesigned cabs and improved boom speeds. Over another aisle **Caterpillar** will highlight its recently launched 2,500kg/ 5.6 metre compact TH255C.

Moving towards the centre of the Gold Lot check in on **Haulotte** and then on to **Skyjack** with its VR1056 and ZB2044 telehandlers now fitted with Tier IV Interim engines and other improvements. Further down the main aisle we expect Manitex to have machines from new Italian entrant **Magni**. Over the aisle

Bobcat/Doosan is launching the fourth model in its VersaHandler line - the V417 Versahandler TCC - and the first to feature the Bob-Tach attachment mounting system.

Crossing the road by bridge brings you to the North Hall, where you will find **Gehl** and **Manitou**. Gehl is unveiling an optional lifting hook for its RS telehandlers, while Manitou has a new heavy-duty telehandler aimed at the mining and infrastructure markets. Other machines include the 22.5 tonne/10 metre MHT 10225 which claims to be the world's largest telehandler and three updated MRT 360 degree telehandlers - the MRT 1840 Easy, the MRT 2150 Privilege Plus and the four tonne 24.6m/81ft MRT 2540 Privilege Plus.

Head outside into the Silver Lot you will find **Pettibone** and then head through the Sany stand to **Merlo** - strong in Canada, but relatively new to the US market and attending Conexpo for the first time - with distributor AMS. Across the aisle is Xtreme and Snorkel. **Xtreme** will have two new telehandlers - one compact and one ultra-heavy duty. The compact 5919 has a maximum lift capacity of 5,990lbs/2.7 tonnes and 19ft/5.9m lift height. The ultra-heavy duty 6538 has a 65,000lb/29.5 tonnes capacity and a 11.5m/38ft lift height making it a world champion telehandler.

Snorkel has plans to enter the telehandler market, initially with a couple of mid-range North American models and then later a new range of European models! Nearby you will find **Sennebogen** which builds heavy duty handlers, but does not plan to have any on show. Over the aisle **Wacker Neuson** is showing a couple of its compact machines.

Finally in Silver Lot 4 Spanish telehandler manufacturer **Ausa** is showing several of its ultra compact telehandlers, including its smallest model in its range - the 1,350kg/3.99 metre T144 HX4.



Gehl RS10-55



JCB 525-60

FAYMONVILLE

TRAILERS TO THE **MAX**

VISIT US AT



STAND 3611
SILVER LOT 1



FAYMONVILLE DISTRIBUTION AG

Duarrefstrooss 8 | L-9990 WEISWAMPACH | T: +352 26 90 04 155 | F: +352 26 90 04 425 | sales@faymonville.com

www.faymonville.com



Get the whole story...

cranes & access

...follow us on

[facebook](#)

[twitter](#)

Vertical
net



MERLO

10112 Industrial Drive, Pineville, NC 28134
www.AMS-Merlo.com | (704) 552-8180

VISIT US AT



SILVER LOT 2
BOOTH 4200



World Leaders in Handler Design

- Load capacities from 5,500lbs to 26,500lbs
- Lift heights from 19'-0" to 96'-8"
- Compact stabilizers for safety
- Built in side-shift for precision
- Hydrostatic transmissions
- 360° operator visibility
- Exclusive Merlo "Ring of Steel" for protection
- Optional Boom Suspension System
- Largest in class cabs
- Roto models available with rotating boom
- Numerous attachments available
- Sale and Rental options available



Roto 40.30 MCSS

Manufacturer • Fabricante	Stand	Lot
Ausa	6736	Silver
Bobcat	1501	Gold
Case	11722	North
Caterpillar	1005	Gold
Dieci	2175	Gold
Doosan	1501	Gold
Gehl	12605	North
Genie	1047	Gold
Haulotte	1531	Gold
JCB	1559	Gold
JLG	1037	Gold
Liebherr	2155	Gold
Lull	1037	Gold
Magni	2115	Gold
Manitou	12605	North
Merlo	4200	silver 2
Mustang	12605	North
Pettibone	3149	Silver 1
Sellick	1071	Gold
Sennebogen	4264	Silver 1
Skyjack	1837	Gold
SkyTrak	1037	Gold
Snorkel	4224	Silver 2
Terex	1047	Gold
Wacker Neuson	4452	silver 2
Xtreme	4224	silver 2

Hay un montón de manipuladores telescópicos en la feria de este año con la mayoría de fabricantes representados.

Empezamos el tour con el fabricante italiano **Dieci** que es probable que presente nuevos modelos, pero todavía está tratando de hacerse un hueco en el mercado. Al lado, **Liebherr** aún tiene que lanzar sus manipuladores telescópicos en los EE.UU., sin embargo al otro lado del pasillo, **JCB** está presentando un nuevo modelo de seis toneladas y 2,5 m compacto, el 525-60 Hi-Viz, con motor de montaje lateral y punto de articulación bajo del brazo para mejorar la visibilidad. Sustituye a los modelos antiguos 524-50, 527-55

y los modelos con motor trasero 520-50. Ahora nos dirigimos a **Terex**, donde **Genie** tiene tres manipuladores telescópicos en exposición, incluyendo el Heavy Duty GTH -1544 de 15.000lbs y 6.8 toneladas lanzado el año pasado.

Al otro lado del pasillo llega a **JLG**, **Lull** y **SkyTrak**. JLG incluye dos nuevas máquinas especial alquiler - JLG 3614RS y 4017RS - dice que ofrecen un menor costo de propiedad y son más fácil de



Merlo P3814



Skyjack VR1056D



Genie GTH 1544

mantener. El mayor lanzamiento lo podemos encontrar en los SkyTrak 10054 y 8042, con mejoras sustanciales de diseño - sin perder sus credenciales de manipulador telescópico americano" - incluyendo el manejo mediante palanca única, cabinas rediseñadas y mejoradas velocidades de elevación. En el otro pasillo **Caterpillar** destacará su recientemente lanzado TH255C compacto de 2500kg/5,6 metros.

Hacia el centro de la Gold Lot pare en el stand de **Haulotte** y luego en **Skyjack** con sus manipuladores telescópicos VR1056 y ZB2044 ahora equipados con motores Tier IV Interim y otras mejoras. Más abajo en el pasillo principal **Manitex** tendrá las máquinas del nuevo operador italiano **Magni**. A lo largo del pasillo **Bobcat/Doosan** está lanzando el cuarto modelo de su línea VersaHandler - el V417 Versahandler TCC - y es el primero en ofrecer el sistema de montaje de fijación Bob-Tach.

Cruce la carretera por el puente que lleva a la Sala Norte, donde encontrará **Gehl** y **Manitou**. **Gehl** está presentando un gancho de elevación opcional para sus manipuladores telescópicos RS,

mientras **Manitou** tiene un nuevo manipulador telescópico resistente destinado a los mercados de minería e infraestructura. Otras máquinas incluyen el MHT 10225 de 22,5 tonne/10 metros, que pretende ser el manipulador telescópico más grande del mundo y tres actualizadas rotatorias MRT 360 - MRT 1840 Easy y el MRT 2150 Privilege Plus y el MRT 2540 Privilege Plus de cuatro toneladas 24.6m/81ft.

Fuera del Silver Lot encontrará **Pettibone** y vaya a través de la Sany a **Merlo** - que es fuerte en Canadá, pero relativamente nuevo en el mercado de los EE.UU. y asisten a Conexpo por primera vez, con la distribuidora AMS. Al otro lado del pasillo está **Xtreme** y **Snorkel**. Xtreme contará con dos nuevos manipuladores telescópicos compactos - uno de servicio ultra-pesado. El compacto 5919 tiene una capacidad de elevación máxima de 5.990 toneladas/2.7lbs y altura de elevación 19ft/5.9m. El ultra-pesado 6538 tiene una capacidad de 65.000 toneladas/29.5lb y una altura de elevación de 11.5m/38ft. Snorkel tiene planeado entrar en el mercado del manipulador telescópico, en un principio con un par de modelos norteamericanos de gama media y más tarde una nueva gama de modelos europeos. Cerca se encuentra **Sennebogen** que construye los manipuladores de trabajo pesado, pero no va a tener ninguno en la feria. A lo largo del pasillo **Wacker Neuson** está mostrando un par de sus máquinas compactas.

Finalmente en el Silver Lot 4, el fabricante de manipuladores telescópicos español **Ausa** está mostrando varias de sus manipuladores telescópicos ultra compactos, incluyendo el modelo más pequeño de su gama - el T144 HX4 de 1350 kg/3.99 metros.



Manitou MHT 10225



Skytrak-8042

MAT & TIMBER SERVICES



CRANE MATS
OUTRIGGER MATS
TEMPORARY ACCESS ROADS
RAMPS

For all types of cranes under any application - Nationwide and Overseas



TEL: +44 (0) 1264 811005
FAX: +44 (0) 1264 810600

e-mail: info@sarumhardwood.co.uk web site: www.sarumhardwood.co.uk



ANTI-COLLISION FOR CRANES
The International Expertise



Visit us on **Platinum Lot 8676** to discover



The New Generation of Anti-Collision

Easy to install and evolutive
User friendly and easy to program
Innovative, it combines **Safety, Productivity and Profitability** in a single new jobsite solution

Beyond anti-collision, ProSITE helps you managing your cranes daily activities.

Anti-collision and Zoning systems – Site Supervision – Anemometers – Airbeacons

Manufacturer • Fabricante	Stand	Lot
Remote Controls		
Autec	6773	Silver 4
HBC-radiomatic	52872	Central
Hetronic	1171	Gold
Ikusi	82918	South
Scanreco	3291	Silver 1
Tele Radio	760	Hotel
Electronics & Safety		
3B6/Cobo	85201	South
Ascorel	50963	Central 3
Cobo	85201	South
Curtiss Wright Controls	83434	South
Cranesmart Systems	1393	Gold
Deltatech controls	84034	South
GKD Technik	40424	Central
Hirschmann (PAT)	2024	Gold
Hoistcam	90427	Platinum
HookCam	2674	Gold
LSI	2761	Gold
Moba	50063	Central
NBB Controls	50932	Central
OEM Controllers	80707	South
Orlaco	2771	Gold
PAT/Hirschmann	2024	Gold
Penny & Giles	83434	South
P-Q Controllers	82021	South
Rayco Wylie	2755	Gold
Sigalarm	70112	Gold Hall
SMIE	8676	Platinum
Trimble	61046	South 1

To reach all of the exhibitors – including remote control manufacturers, electronics and safety systems will require visiting every hall, so you may wish use the listing to select what you want to see.

If not begin in the Gold Lot where most crane management and load moment indicator producers can be found, with key company's **LSI**, **Hirschmann** as well as remote control company **Hetronic**. You might also check out the crane cameras, including **Hookcam** and **Orlaco**, before heading over the road, past **Scanreco** in Silver 1, to the Central hall for companies such as **HBC-radiomatic** which has several new products, including the Photon which displays several live camera images simultaneously on the controller screen, technos 2 and radiomatic report. Next stop is the South Hall for **3B6** and most of the joystick manufacturers. While there, do stop by **Moba**, which likes to show off new ideas concepts and technology at major shows. Now its outside to Silver Lot 4 where you will find **Autec** to see its new ARX receiver and

Supervised Operator system (SOS) allowing a supervisor use a second transmitting unit to override an operator that has got into a dangerous situation. Finally get on the shuttle to go down to the Platinum Lot where you will find anti-Collision specialist **SMIE** which has a new remote crane management system which is worth seeing, along with **Hoistcam**.



Para llegar a todos los expositores - incluyendo fabricantes de control remoto, sistemas electrónicos y de seguridad requeriría visitar todas las pabellones, por lo que puede que desee utilizar la lista para seleccionar lo que desea ver. Comience en el Gold Lot donde la mayoría de los productores de indicadores de gestión de la grúa y de momento de carga se pueden encontrar, con **LSI**, **Hirschmann** así como la empresa de control remoto **Hetronic**. También puede revisar las cámaras de la grúa, incluyendo **Hookcam** y **Orlaco**, antes de dirigirse a la carretera, pase **Scanreco** en Silver 1, a la sala central para empresas como **HBC** que tiene varios productos nuevos, entre ellos el Photon, que muestra varias imágenes en vivo de la cámara al mismo tiempo sobre la

pantalla de control, Technos 2 y el informe radiomatic. La próxima parada - el Salón Sur es **3B6** y la mayoría de los fabricantes de joystick. Allí pare en **Moba**, que le gusta mostrar nuevos conceptos ideas y la tecnología en las ferias más importantes. Ahora salga al exterior al Silver Lot 4, donde encontrará **Autec** para ver su nuevo receptor ARX y el sistema de operador Supervisado (SOS), que permite a un supervisor utiliza una segunda unidad de transmisión para anular un operador que se ha metido en una situación peligrosa. Finalmente consiga un transporte para ir hasta el Platinum lot donde se encuentra el especialista en anti- colisión **SMIE** que tiene un nuevo sistema de gestión de gancho remoto de la grúa que es digno de ver, junto con **Hoistcam**.



**Strong winches
for many applications**

ROTZLER®

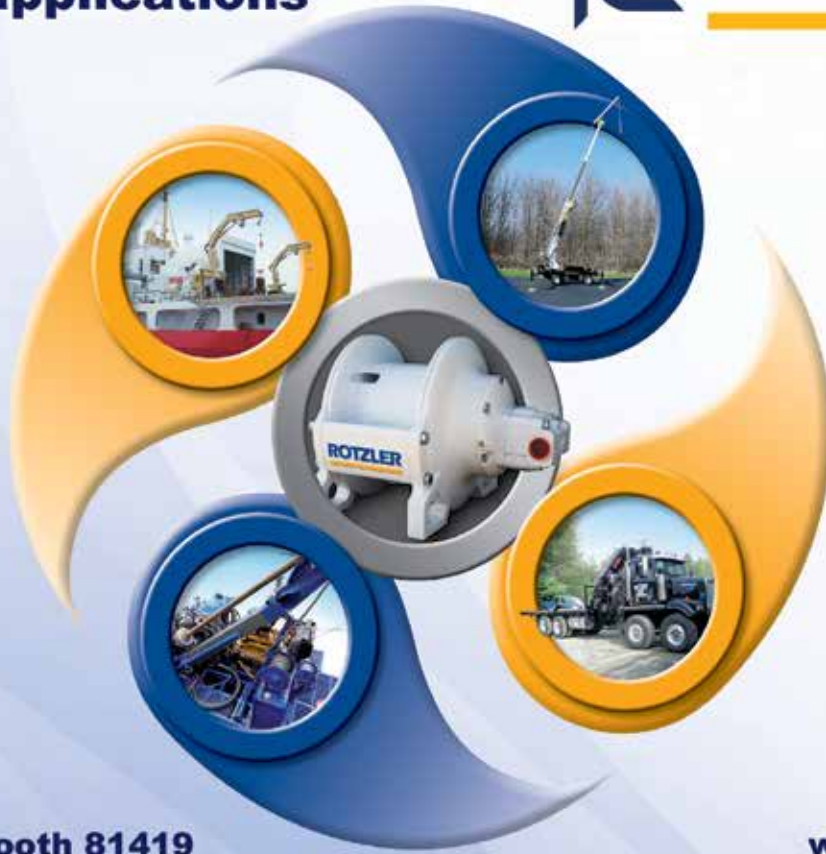

South Hall 3, Booth 81419

www.rotzler.com

NYLACAST
ENGINEERING PLASTIC SOLUTIONS

EVERYDAY SUPERHEROES

Custom components and materials with:

- Exceptional resistance to wear and abrasion
- High impact strength
- High load capacity
- Self lubricating materials
- Low coefficient of friction
- Lightweight - 1/7th of steel
- 25 x the life of phosphor bronze
- Reduced maintenance needs and machine downtime
- Custom formulation of materials



Scan this advert with the layar app to access exclusive content

in t+ YouTube



DISCOVER MORE ABOUT THE NYLA-HEROES BY VISITING:

WWW-NYLA-HEROES.COM

NYLACAST
PIONEERS OF THE ORIGINAL OIL FILLED NYLONS
OIL & NYLUBE



Visit us at
Stand 40527

+44 (0)116 276 8558
construction@nylcast.com
www.nylcast.com

Manufacturer • Fabricante	Stand	Lot
Tires/Tyres		
BKT Tires	70050	Gold Hall
Bridgestone	13006	North
Continental Tire	9494	Platinum
Double Coin tires	65401	Silver 4
Goodyear	11649	North
Michelin	10378	North
Magna Tyres	3711	Silver 1
Solideal - Complast	40322	Central
Titan Tire and Wheel	11671	North
Yokohama Tire	30412	Central
Engines		
Cummins	84808	South
Deutz	84620	South
Hatz Diesel	83740	South
Honda	84030	South
Kohler	7127	Platinum
Kubota	84608	South
MTU	84630	South
Perkins/Cat	84318	South
Yanmar	11671	North
Components		
ADB Slew rings	70049	Gold Hall
Allison Transmission	85430	South
Auburn Gear	8111	South
Axle Tech	84830	South
Bonfiglioli Riduttori	80642	South
BorgWarner	85408	South
Bosch Rexroth	80216	South
Brand Hydraulics	81507	South
Brevini	2971	Gold
Bucher Hydraulics	82829	South
BVA Hydraulics	82740	South
Changzhou Aoxuan	508	Hotel
Comer	82130	South
Concentric Rockford	80908	South
Dakota Fluid Power	83344	South
Dana	85114	South
Danfoss	80529	South
Dinamic Oil	83640	South
DLH fluid power	81818	South
Donaldson filter	83940	South
Dynamic Fluid Comp	82818	South
Eagle Hydraulics	81511	South
Eaton	80230	South 3
Fairfield	81529	South
Force America	82522	South
Gardner Denver	64015	South
Gates	80516	South
Grear	83130	South
HAWE Hydraulics	81215	South
HBS	8576	Platinum
Helac	30934	Central 1
Hunger Hydraulics	82212	South
Hydraforce	80930	South
Hydrocontrol	82507	South
Hydratech pumps	85318	South
Kessler	83501	South
KTI Hydraulics	81922	South
Ligon	83122	South
Linde Hydraulics	81318	South
Lube-A-Boom	1888	Gold
Maanshan Fang Yuan	53145	Central
Magantek	81147	South
Manuli Hydraulics	81708	South
Marooka	1537	Gold
North American Hyd	82620	South
Nylacast	40527	Central
Oerlikon Fairfield	81529	South
Omni Gear	83534	South
Parker Hanifin	80440	silver 3
Pirtek	8224	Platinum
Poclain Hydraulics	80940	South
Ramsey Industries	6710	Silver 4
Reel-O-Matic	1888	Gold
Rexroth	80216	South 3
Ryco Hydraulics	82018	South
SAI Hydraulics	82530	South

Sauer-Danfoss	80529	South
Solideal	40322	Central
Spartan Mats	6576	Silver 4
SSAB	30611	Central 1
Sun Hydraulics	80719	South
Texas Hydraulics	81618	South
Tieffe	83418	South
Trelleborg	81929	South
TWG - Tulsa Winch	83130	South
Warn	453	Hotel
Weber Hydraulik	83108	South
White Drive	81107	South
Yates Industries	81921	South
ZF	85030	South
Lifting Equipment		
Allied Power Prod	70141	Gold Hall
Alturamats	61419	South 1
Big Astor	3800	Silver 1
Braden winch	4048	Silver 1
Bridgwell Mats	51104	Central
Crosby	30334	Central
DICA	63731	south
Enerpac	3749	Silver 1
Gearmatic	4048	Silver 1
GKS Lifting & Moving	90527	Platinum
Groundmats	9600	Platinum
Gunnebo Johnson	2842	Gold
Harrington Hoists	70306	Gold Hall
Ind Lift and Hoist	1421	Gold
Kinshofer	3510	Silver 1
Lift Systems	1097	Gold
LGH	3345	Silver 1
Lifting Technologies	2979	Gold
Miller Lifting	2854	Gold
Nylacast	40527	Central
Quality Mat Co	30303	Central 1
Rotzler	81419	south
RUD Chain	70332	Gold Hall
Spanco	61542	Platinum
Sumner	50930	Central
Taylor	6720	Silver 4
Winlet	2765	Gold
Wire Rope		
Alpwire	70043	Hotel
Assoc Wire Rope & Rigging	2852	Gold
Bridon	52828	Central
Casar	50040	Central
Teufelberger Seil	614	Hotel
Wire Co	50040	Central
Wirerope Works	70209	Gold Hall



Once again a large number of component manufacturers are attending, along with producers of lifting gear, safety equipment, tyres, wire rope and engines. Progress on this front has been significant so a visit to the South and Central halls could be well worthwhile.



Una vez más un gran número de fabricantes de componentes están exponiendo, junto con los fabricantes de aparatos elevadores, equipos de seguridad, neumáticos, cables de acero y motores de progreso en este frente son importantes, por lo que una visita a los pasillos centrales del Sur podría valer la pena.

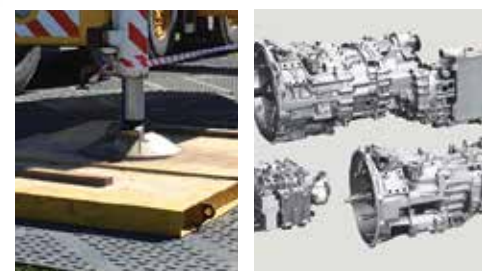

CITY MAP

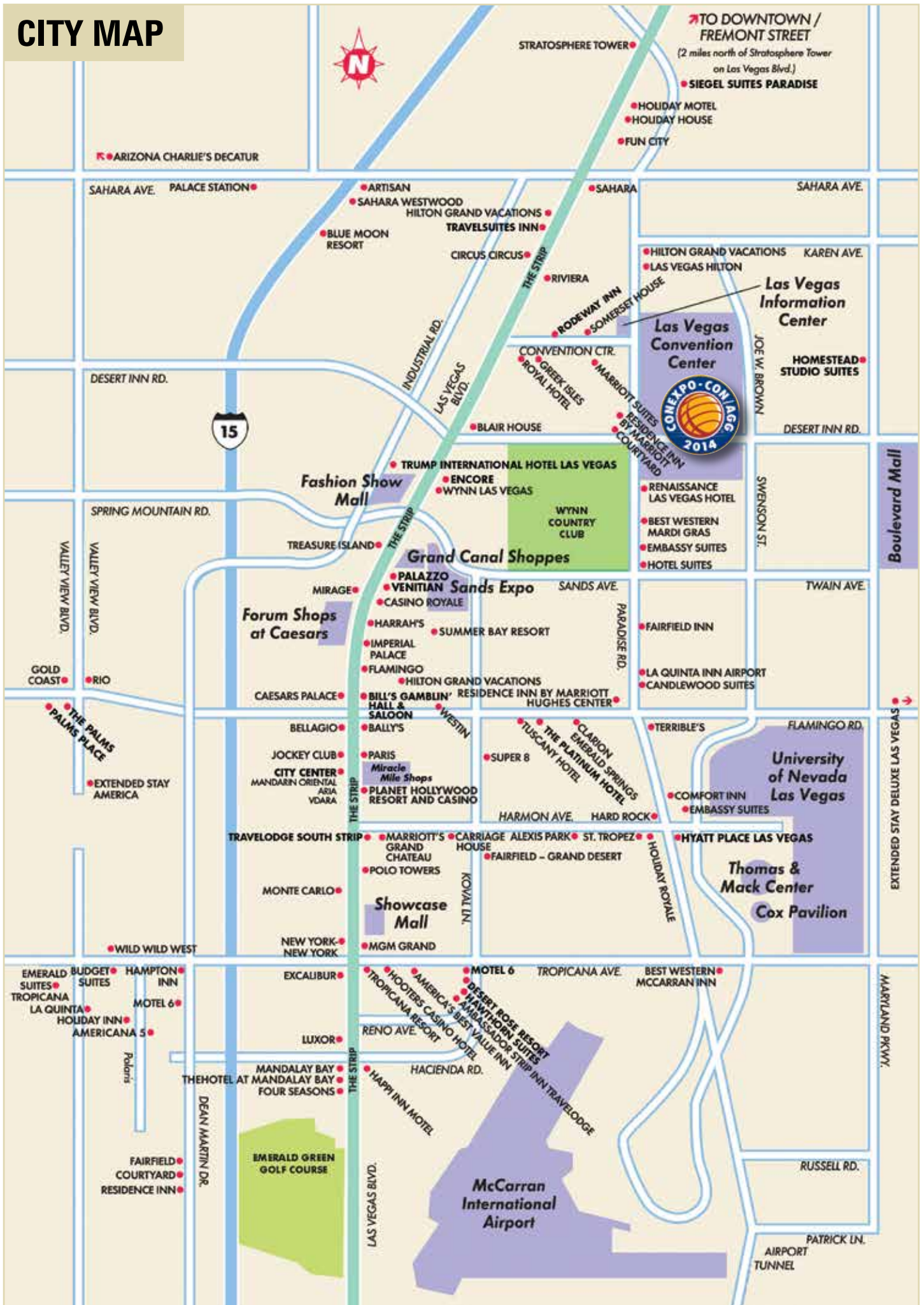

With rapid development of the city, traffic on the strip has become hugely congested at certain times of the day. This is exasperated by very long traffic lights at all major intersections. It can take as long as 50 minutes to go from one end of the strip to the other during peak times.

Shuttle Bus

Conexpo has organised free shuttle bus services between the convention centre and most major hotels during the show.

Taxi cab

Taxi cabs are generally only available from the front of hotels. You can hail one in the street, but succeeding at this during a busy show week is about as likely as seeing a flying pig. Taxis tend to avoid the strip due to the traffic and take alternative roads, this can make the trip seem very circuitous, it does not necessarily mean your driver is scalping you, it is almost always faster. All cabs



have meters and charge a fixed fee of \$3.30 plus \$2.60 a mile or 50 cents a minute when stationary. There is a \$2.00 addition for airport pick-ups. Las Vegas drivers expect a decent tip and can get very unpleasant if you only give them a few cents. A couple of dollars on a \$10 to \$15 charge usually avoids the trail of insults. When everyone is heading out for the evening you can be subjected to a long wait in line, here are some alternatives:

Take the bus

The Deuce is a double deck bus that runs up and down the strip all day, the cost is \$6 for a two hour or \$8 for a 24 hour pass. You must though have the exact change, you will not get on the bus unless you do. The service is hugely popular and even though there are buses every few minutes, they are invariably packed at peak times perhaps not during Conexpo when fewer bus type people are in town? It is also subject to vagaries of Strip traffic so can be slower than walking.



Go with the Monorail

This is fast and predictable taking 15 minutes in total to run from one end of the strip to the other. However it only runs on one side of the strip,

behind the big hotels like Ballys and MGM, so getting to a station from hotels on the opposite side can be a long walk. If you are going to or from the show a general rule of thumb is that the further you are away from the convention centre the more attractive a proposition it is. The Monorail operates from 7 am to 2 am (3 am on weekends) A free shuttle bus runs to Sams Town and Rio hotels to the Monorail station. A two hour ticket is \$6.00, twenty four hours is \$10.80 and a three day is \$24.00.



Con un desarrollo rápido de la ciudad, los atascos en la calle principal son un engorro a ciertas horas del día. Es consecuencia de la cantidad de semáforos que hay en cada esquina. Puede llevarle hasta 50 minutos cruzar de una punta a la otra del strip (calle principal).

Transporte en autobus

Conexpo ha organizado un servicio gratuito de autobuses entre la feria y la mayoría de los principales hoteles.

Taxis

Los taxis están generalmente solo disponibles en los hoteles principales, puede intentar parar alguno desde la calle, pero sera casi tan imposible como ver un cerdo volando. Los taxis tienden a evitar la calle principal y tomar calles alternativas, no crea que le están engañando, sino que esto es muchas veces la alternativa más rápida. Todos los taxis cuentan con taxímetro y cobran fijo \$3.30 más \$2.60 por milla o 50 centavos el minuto si está parado. Los taxistas



de Las Vegas normalmente esperan buenas propinas y no se lo toman muy bien si solo se les da unos centavos. Evitará malas caras si en una carrera de \$10 a \$15 les da dos dólares. Cuando cae la tarde y todo el mundo tiene prisa por llegar a sus citas, algunas alternativas son estas:

Coger el autobús

El Deuce es un autobús de dos plantas que funciona por toda la calle principal durante todo el día, el coste son \$6 un billete o \$8



un billete para todo el día. Debe llevar cambio exacto, si no, no le darán cambio. Hay mucho flujo de autobuses, aunque en horas puntas van bastante llenos. ¿Aunque a lo mejor la gente de Conexpo no se mueve en este tipo de transporte? Teniendo en cuenta el tráfico, habrá veces que llegue antes andando que en autobús.

Ir en Monorail

Una forma rápida de llegar de una punta a otra de la calle principal, en solo 15 minutos. Pero solo va por un lado de los hoteles, por detrás de hoteles como el Ballys y MGM, por lo que llegar a una de las estaciones desde un hotel puede resultar una larga caminata. El Monorail opera desde las 7.00 am hasta las 2 am (3 am en fines de semana).

Un billete de ida son \$6. Hay un billete de 24 horas que cuesta \$10.80. Un billete para tres días son \$24. Hay disponibles otras ofertas.



MONORAIL MAP



MGM GRAND STATION

- Closest station to:**
- Mandalay Bay
 - Mandalay Bay
 - Convention Center
 - Four Seasons
 - Luxor
 - Excelsior
 - Tropicana
 - Hooters Casino Hotel
 - Desert Rose Resort
 - MGM Grand
 - Fashion Outlets of Las Vegas
 - Shoppers' Shuttle
 - Showcase Mall
 - Monte Carlo
 - McCarran Int'l Airport (not in walking distance)
 - Marrriott's Grand Chateau
 - The Signature at MGM Grand

BALLY'S PARIS LAS VEGAS STATION

- Closest station to:**
- Bellagio
 - Planet Hollywood
 - Miracle Mile Shops
 - Elara, a Hilton Grand Vacations Hotel
 - Paris Las Vegas
 - Bally's Las Vegas
 - Super 8 Las Vegas
 - Ellis Island Casino & Brewery
 - Platinum
 - ARIA Resort & Casino
 - Vdara Hotel & Spa
 - Mandarin Oriental Las Vegas
 - Veer Towers
 - Crystals at CityCenter
 - Cosmopolitan

FLAMINGO/ CAESARS PALACE STATION

- Closest station to:**
- Caesars Palace
 - Nobu Hotel at Caesars Palace
 - Flamingo Las Vegas
 - Hilton Grand Vacations (at Flamingo)
 - The Linq
 - High Roller - Coming Soon
 - Westin Las Vegas Hotel
 - Battista's Hole in the Wall Restaurant

HARRAH'S/ THE QUAD STATION

- Closest station to:**
- Forum Shops at Caesars
 - The Quad Resort & Casino
 - Harrah's Las Vegas
 - Rio (via Harrah's shuttle)
 - The Linq
 - High Roller - Coming Soon
 - Casino Royale
 - The Venetian
 - Grand Canal Shoppes
 - Mirage Las Vegas
 - TI (Treasure Island)
 - Fashion Show
 - Trump International
 - Hotel & Tower
 - Sands Expo
 - Wynn Las Vegas
 - Encore Las Vegas

LAS VEGAS CONVENTION CENTER STATION

- Closest station to:**
- Clarion Hotel & Casino (formerly Greek Isles)
 - Las Vegas Marriott
 - Residence Inn Las Vegas
 - Convention Center
 - Courtyard by Marriott
 - Embassy Suites
 - Best Western Mardi Gras Las Vegas
 - Rennaissance Las Vegas
 - Las Vegas
 - Convention Center
 - Visitor Information Center

LVH STATION

- Closest station to:**
- LVH - Las Vegas Hotel & Casino
 - Hilton Grand Vacations
 - (at LVH)
 - Turberry Place
 - SpringHill Suites by Marriott
 - Riviera
 - Circus Circus

SAHARA STATION

- Monorail station access via street level on Sahara Ave. and Paradise Rd.**
- Closest station to:**
- Hilton Grand Vacations (on Strip)
 - Stratosphere
 - Downtown Las Vegas (via RTC transit)

Sights not to miss!

There are a great deal of things to see in Las Vegas and many of them are free, we like that! Here are just a few of them.



The fountains at Bellagio. More than a 1,000 fountains soar up to 240ft/73m as they perform a ballet to classic songs and music, every half hour in the afternoons and then every 15 minutes from 8pm till midnight. Inspiring!

The pirates and sirens battle at Treasure Island occurs every 90 minutes at 19:00, 20:30, 22:00 & 23:30 with a band of pirates battling it out with a bevy of buxom sirens, great pyrotechnics this one is a traffic stopper.

The Shark Reef at Mandalay Bay, a visit is not cheap but well worth seeing this 1.3 million gallon/6 million litre tank with walkways through it.



A few years ago the downtown street outside the **Golden Nugget** was roofed in with millions of light bulbs fitted to the inside to produce a jaw dropping light show with 540,000 watts of music that is jaw droppingly incredible - every hour on the hour after dark.



The Mirage Volcano and waterfall, the volcano goes off every 15 minutes at night spewing fire over 100ft/30m into the air as massive volumes of water tip over the edge.

The original Las Vegas glitz **Glitter Gulch** is the short narrow street incandescent with light bulbs and original neon!

The Lion habitat at MGM Grand a free attraction showing off its collection of big cats.

The show at Circus Circus has often included famous acts and changes every half hour till midnight.

M&M World, yes really, is an attraction that includes a 3-D movie at the MGM and it's free.

The view from the top of the **Stratosphere tower** is amazing and if you are a little unbalanced there are also some crazy amusement rides.

The Fremont street experience.

The Forum shops at **Ceasars**



Palace, with its sky ceiling and animated statues, a show is held every hour.

The Gondolas and minstrels at the Venetian not to mention the St Marks square where you seem to be outside.

The art collection at the Bellagio, some of the worlds finest and most expensive pieces. A Monet exhibition is on this week, entrance fee is \$15.

The Musical artefact displays at the **Hard Rock hotel and casino.**

The world's largest gold nugget at where else? - **the Golden Nugget.**

The Strip at night try the view from the bar at the top of the Rio.

Paris, the Eifel tower might only be half size but the lights replicate those fitted for the 100th anniversary on the original tower and it was built to Gustave Eifels original drawings.



Cosas que no debe perderser!

Hay muchas cosas que ver en Las Vegas y muchas de ellas son gratis, eso nos gusta! Aquí están algunas de ellas.

Las fuentes en el Bellagio, más de 1000 fuentes planean por 240ft/73m mientras realizan un ballet con canciones de música clásica, cada media hora por las tardes y cada 15 minutos a partir de las 8:00 pm hasta media noche. Inspiador!



La batalla de piratas y sirenas en Treasure Island - 19:00, 20:30, 22:00 & 23:30 con una banda de piratas en plena batalla contra unas



exuberantes sirenas, gran pirotécnia, es una parada muy concurrida.

La Calle Fremont Hace años el downtown de la ciudad fuera del **Golden Nugget** estaba techado con millones de bombillas que te dejaban la boca abierta con 540,000 watos de música - cada hora a partir de que se vaya el sol.



La ostentación de **Las Vegas Glitter Gulch** es la calle estrecha incandescente con bombillas y neón!

El Volcán del Mirage y la cascada, el volcán es cada 15 minutos por la noche echando fuego a 100 ft/30m mientras grandes cantidades de agua se caen sobre el filo.

El Arrecife de tiburones (Shark Reef) en **Mandalay Bay,** una visita nada barata pero que merece la pena con



su pecera de 1.3 millones de galones /6 millones de litros con pasillos para pasar por debajo.

El Habitat de Leones en el MGM Grand una atracción libre que muestra sus felinos.

El espectáculo en el **Circus Circus** normalmente ha incluido números famosos y cambios cada media hora hasta media noche.

M&M World, si de verdad, es una atracción que incluye una película en 3D en el MGM y es gratis.

La vista desde la **torre Stratosphere** es espectacular y si no le da miedo hay algunas atracciones encima de la torre.

Las Tiendas del Forum en el **Ceasars Palace,** con su cielo y estatuas animadas, con un espectáculo cada hora.



Las Gondolas y Trovadores en el **Venetian** por no mencionar la Plaza de San Marcos donde parece que estás a la intemperie.

La colección de arte del Bellagio, con piezas muy caras, hay una exposición de Monet esta semana, por \$15 la entrada.

Todo sobre la Música en el **hotel y casino Hard Rock.**

La nuez más grande del mundo de oro donde estará? En el **Golden Nugget.**

El Strip (calle principal) de noche, pruebe la vista desde el bar en lo alto del Rio.

Paris, la torre Eifel puede que sea la mitad en tamaño que la original, pero la replica es exquisita y las luces se pusieron en su 100º aniversario y se construyó según los planos originales de Gustave Eifels.



Restaurants and Bars a Vertikal Guide

Here is our selection of places to eat and hang out. The selection is entirely arbitrary, ones we have tried or those influenced by friends, locals and just because they took our fancy...



Choice you certainly have in Las Vegas, from the very finest haute cuisine (yes really) to the most mind bogglingly amazing buffets to highly themed novelty restaurants where the food is almost an afterthought and everything in between. Be warned that during Conexpo the better places will be tough to get into and even if you do reserve, after 8:00 be prepared, at least in the mid-range restaurants, for your table not to be available until well after the time you reserved; Sounds like the crane business!

Andrés

One of the longest established restaurants in Las Vegas having opened in 1980. The original Andrés is still an excellent French restaurant. Pricy but good and located in a quiet neighbourhood. The 1930's building has private rooms that can be reserved.

401 South Sixth Street Tel: 385-5016

Aureole

If you are a wine buff this might be just the place for you, the restaurant is built around a four storey glass wine storage tower. The wine list is a computer tablet, allowing to search by country, grape variety or whatever, with some 800 cabernets for example, it is a bit of gimmick and expensive. The food is good but not great, the prix fixe menu is \$75 with supplements but if you are out to impress?

Mandalay Bay: Tel: 632-7401

Bouchon

A fantastic bistro, with excellent seafood, lamb and other dishes. In a great setting you might try and get a table on the outside terrace although they are in high demand given the quality this restaurant offers and excellent value.

The Venetian: Tel: 414-6200



Craftsteak

A clone of the famous New York eatery, if you are looking for grilled meat this is the place to come. Simple good quality food and decor, some of the best steaks in town, with more exotic fare, such as Kobe beef tartare, quail or sweatbreads also on the menu.

**MGM Grand Studio Walk:
Tel: 891-7318**

Jimmy Buffets Margaritaville

Just across the street from Caesars Palace, this is a chain - a small one though - a Caribbean Pub for 'parrot heads' with what it describes as comfort food from warm places on the planet. That and great Margaritas - might be just the ticket by Thursday evening! **355 Las Vegas Blvd:**

Tel: 733-3302



Joess Seafood Steak & Stone Crab

A noisy popular restaurant whose name says exactly what it does. You will need to book but it is worth it. If you order its 'signature steak' the 22 ounce Porterhouse we suggest you share it with someone. If you never had fried green tomatoes this is the place.

**Forum at Caesars Palace:
Tel: 792-9222**

Roy's Hawaiian

Although essentially a chain Roy's is very popular and one of just 24 locations outside of Hawaii, where Roy Yamaguchi first opened in 1988. Described as fine dining Hawaiian Fusion cuisine it has a varied menu including meat, seafood, ribs and Yamaguchi Sushi. **620 East Flamingo Road, Tel: 691-2053**

Pamplemousse

Another long established country French restaurant! Less expensive and some say slipping a bit, There is no written menu here, you start with a big basket of fresh crudités and then the waiter will tell you what they are cooking as it changes depending on what is good at the market. Don't worry you will still be spoilt for choice.

400 E. Sahara Ave Tel: 733-2066



PF Changs

Another chain but this Chinese/Thai restaurant has a great atmosphere good food and a modest price. But a word of warning it is constantly crowded and you may have to wait. There are three in town we tried the one on Paradise Avenue.

4165 Paradise Rd Tel: 792-2207

Redwood Bar and Grill

If you are looking for a great piece of beef and good value then you can do a lot worse than ask for 'the porterhouse special' at the Redwood, it is not on the menu but they will know what you want. Meals come with soup or salad and vegetables all for around \$20. This is downtown, a good place to eat if you want to explore the downtown area one evening

The Californial: Tel: 385-1222

Tableau

Tableau serves American and Mediteranean food in a beautiful French inspired dining room, if the terrace is open this would be our choice for overlooking one of the pools. The food is excellent and given its quality reasonable value and good service.

The Wynn: Tel: 248-3463

The Hofbrauhaus

Is this a hang over from Vertikal Bauma? While risking the derision of those German readers who consider the original Hofbrauhaus in Munich is tacky enough, the beer and some of the food is shipped in from Bavaria, so if you are desperate for a good German beer this might be the place to go. It is off the strip but they have a free shuttle.

Ventano

We had to have a proper Italian! The Ventano is a rustic Italian in Henderson with a fantastic view from its wraparound terrace with views of the mountains. Lively and friendly and unpretentious good value.

**191 Arroyo Grande, Henderson
Tel: 944-4848**

Voo Doo Steak

Located at the top of the Rio tower New Orleans cuisine including crawfish and Blue crab cakes. Excellent bar as well and you can see the whole city from up here.

Rio Hotel: Tel: 777-7923

Wolfgang Puck

Yes another chain! But we hear that this is one of the best and great value, California cuisine, wide range of dishes from steaks to sausages, calf livers and more.

MGM Grand: Tel: 891-3000

Buffets

If Buffets are your scene then Las Vegas is your heaven. We hear that the following are among the best:

The **Planet Hollywood spice market** and the **Rio Carnival World Buffets**, And as you might expect the **Wynn** and **Bellagio** buffets consistently rate among the best. **Le Village at Paris** has stations representing different regions of France and is also said to be very good...If you like buffets that is.



Bars

We didn't leave much space for bars, the **Ghost bar** at the **Palms** is supposedly the place of the moment and has great views, then the **House of Blues** in the **Mandalay Bay** always rates highly, a restaurant by day a nightclub by night, it is apparently somewhere not to miss. If you are looking for a throwback to the Las Vegas of the 1970's try the **Casbar Lounge** in the **Sahara** and of course the top of the **Rio**.



Restaurantes y Bares Una Guía de Vertikal

Aquí está nuestra selección de lugares para comer y salir, la selección es totalmente arbitraria, unos que ya hemos probado y otros recomendados por amigos, horiundos y porque tienen Buena pinta...



Desde luego tiene donde elegir en Las Vegas, desde la alta cocina (de verdad) o los más impresionantes buffets hasta los nuevos restaurantes temáticos donde la comida es lo de menos. Tenga en cuenta que durante la feria de Conexpo los mejores sitios estarán llenos e incluso reservando, después de las 8:00 prepárese, al menos en los restaurantes de gama media, para esperar un buen rato su mesa; suena como el negocio de las grúas!

Andrés

Uno de los restaurantes con más solera de Las Vegas. Abrió en 1980, el Andrés original es todavía un restaurante francés excelente. Algo caro pero bueno y situado en un barrio tranquilo. El edificio de 1930 cuenta con reservados.

401 South Sixth Street
Tel: 385-501 6

Aureole

Si Ud. es aficionado al vino este puede ser su lugar, el restaurante se ha construido alrededor de una torre de almacenaje de vino de 4 pisos de cristal. La carta de vinos es una carta computerizada, permitiendo buscar por países, variedad de uva o lo que sea, con más de 800 cabernets por ejemplo, es un poco un truco de promoción y caro. La comida es buena pero no excelente, el precio del menú es fijo de \$75 con suplementos pero si está fuera para impresionar?

Mandalay Bay: Tel: 632-7401

Bouchon

Un fantástico bistro, con excelente marisco, cordero y otros platos, en un gran ambiente puede que consiga una mesa en la terraza de fuera aunque siempre están muy demandadas. De gran calidad, este restaurante ofrece un excelente valor.

The Venetian: Tel: 414-6200

Craftsteak

Un clon del famoso sitio en Nueva Cork, si busca carne a la parrilla este es el lugar al que tiene que ir, buena calidad de comida y buena decoración, hacen unos de los mejores chuletones en la ciudad, con cosas exóticas en la carta, como el tartar de carne de vaca de Kobe, codorniz o mollejas. **MGM Grand Studio Walk: Tel: 891-7318**

Buffet Jimmy Margaritaville

Al otro lado de la calle del Ceasar Palace, se trata de la cadena - aunque una pequeña - un pub caribeño para aquellos que les gusta las buena comida y los lugares calientes del planeta. Eso y grandes Margaritas - podría ser perfecto para el jueves por la noche!

355 Las Vegas Blvd. Tel: 733-3302

Joess Seafood Steak & Stone Crab

Un ruidoso restaurante popular cuyo nombre dice exactamente lo que ofrecen, carne, marisco y cangrejo. Necesita reservar pero merece la pena. Si pide su 'signature steak' de 22 onzas, le sugerimos que lo comparta. Si nunca ha probado los tomates verdes fritos, hágalo aquí.

Forum en el Caesars Palace:

Tel: 792-9222

Roy's Hawaiian

Aunque esencialmente la cadena de Roy es muy conocida y es uno de los 24 sitios que tienen fuera de Hawaii, donde Roy Yamaguchi abrió por primera vez en 1988. Descrita como la refinada cocina de fusión hawaiana tiene un variado menú que incluye carnes, mariscos, costillas y Yamaguchi Sushi. **620 East Flamingo Road, Tel: 691-2053**

Pamplemousse

Otro restaurante francés de gran solera! Menos caro y según algunos ha decaído un poco. No hay carta impresa, se comienza con una gran cesta de crudités y después el camarero le informará sobre lo que están cocinando, ya que depende de lo que sea bueno ese día en el mercado. No se preocupe, tendrá muchas posibilidades.

400 E.Sahara Ave Tel: 733-2066



PF Changs

Otra cadena, pero tipo Chino/Thai, con gran ambiente, buena comida y un precio razonable. Sólo una cosa, está siempre lleno, a lo mejor tendrá que esperar. Hay tres en la ciudad, nosotros probamos el de la Avenida Paraíso.

4165 Paradise Rd Tel: 792-2207

Redwood Bar and Grill

Si busca un buen trozo de buey de calidad puede pedir 'the porterhouse special' en el Redwood, no está en el menú pero sabrán lo que les pide. Las comidas vienen con sopa o ensalada y vegetales, todo por \$20. Está en el centro de la ciudad, por si quiere explorar esa zona de noche.

The Californial: Tel: 385-1222

Tableau

Tableau sirven comida tipo Americana/ mediterránea en unos salones con inspiración francesa. Si la terraza está abierta debería probarla, para echarle un vistazo a las piscinas. La comida es excelente, de calidad y buen servicio.

The Wynn: Tel: 248-3463

The Hofbrauhaus

Es la resaca de Bauma? A riesgo de la irrisión de aquellos lectores alemanes que consideran el Hofbrauhaus original de Munich un poco hortera, la cerveza y alguna comida la traen de Bavaria, por lo que si está desesperado por una buena cerceza alemana este es su sitio. Está fuera de la calle principal, pero ofrecen traslado gratis.

Ventano

Teniamos que incluir un italiano apropiado! El Ventano es un italiano rústico en Henderson con una vista excelente desde su terraza con vistas a las montañas. Muy vivo y acogedor, con comida nada pretenciosa.

191 Arroyo Grande, Henderson
Tel: 944-4848

Voo Doo Steak

Situado en la torre Rio ofrecen comida de Nueva Orleans incluyendo cangrejos de río y pasteles de cangrejo. Un bar excelente, además de poder ver la ciudad desde arriba.

Rio Hotel: Tel: 777-7923



Wolfgang Puck

Otra cadena!! Pero hemos oído que es la mejor, comida de California con una gran cantidad de platos desde carne, carne de ternero, etc.

MGM Grand: Tel: 891-3000

Buffets

Si le encantan los buffets, entonces Las Vegas para Ud. es el cielo. Nos han contado que los siguientes son los mejores:

Los buffets de **Planet Hollywood spice market** y del **Rio Carnival World Buffets**. Y los del **Wynn** y el **Bellagio** también son excelentes. **Le Village at Paris** tiene estaciones que representan diferentes regiones de Francia y dicen que es muy bueno...si es que le gustan los buffets.

Bares

No hemos dejado mucho espacio para los bares, el **Ghost bar** en **Palms** se supone que es el sitio de moda y tiene grandes vistas. Y el **House of Blues** en el hotel **Mandalay Bay** siempre está de moda, un restaurante de día y sitio de copas de noche, por lo que no hay que perderse. Si Ud. busca una vuelata a Las Vegas de los 70, vaya a **Cashbar Lounge** en el **Sahara** y por supuesto la parte de arriba del **Rio**.



It is Gaming not Gambling

Apparently the word gambling, is not considered 'elegant' in Nevada - the word is Gaming! Well Gambling, Gaming, Tomato, Tomayto the game is the same and this is the world capital for it.



You chances of leaving Las Vegas with money in your pocket all depends on what game you play and how well you know the game. One game where the odds are surprisingly in your favour is **Craps**, especially if you know what you are doing. The same applies to **Poker** of course, which has become a lot more popular in recent years.



Blackjack is easier to understand than craps and offers the best odds, which is why it's so popular in Las Vegas. Success though depends on how well you can assess your chances and then make a decision, if you are weak and "wishy-washy" the odds jump in favour of the casino. Confidence and a quick mind are the key, as is quitting when you are ahead and coming back later.

Roulette is the easiest to play but Europeans note that over here there are two zeros, significantly increasing the Casinos odds, only play for fun, the odds are stacked against you, which is why it's less popular.

Keno is a local speciality, originally introduced by Chinese 'coolies' working on the railways, you can

play this almost anywhere in the hotel, thanks to the Keno runners who will take your bets no matter where you are! Keno is a form of lottery, and the odds are poor, it is easy and fun but don't expect to break the bank.

Then of course we have **Slots!** The fact that most of the casinos' income comes from these machines should tell you everything. The problem with slots is that it is easy to get carried away and most people simply put all their winnings right back in! But the fun is to see how long you can last and people do walk away with big jackpots, just not many of them.

One thought that might cheer you, the casino will provide free drinks while you play. So you can save on your bar tab, and know that not all of what you are feeding into the machine is a loss! Do tip the waitress a couple of dollars though, or they may be slow to return.

Most casinos have Slots clubs, if you are going to play frequently join one, you'll get a card and can rack up benefits and obtain discounts even before you play. So if you are taking your gaming seriously... Blackjack and Craps are the games to go for. Casinos offer free lessons each morning. Take them up on it, the dealers will teach you how to win and not only will you enjoy it more but you might also stand a chance of going home with some money in your pocket! I did say might!



Es jugar, no apostar

Aparentemente el mundo de las apuestas no se considera elegante en Nevada, la palabra que hay que utilizar es juego! Ya sea apostar, jugar, Tomate o Tomayto, el juego es el mismo y esta es su capital.



Sin embargo, ¿cuáles son sus posibilidades de salir andando habiendo ganado en un casino en Las Vegas? Depende de los juegos que juegue y lo bien que lo conozca. Uno de los juegos donde los astros están a su favor son los **Dados**, eso a menos que sepa lo que hace.

Lo mismo se puede aplicar al **Blackjack**, que cada vez es más popular. Por otro lado es más fácil de entender y puede tener suerte, por eso es tan popular en Las Vegas, el éxito depende de cómo juegue la partida, si toma una decisión pero duda, la suerte juega a favor del casino. La clave es confianza y juego rápido.

La **ruleta** es todavía más fácil de jugar pero si procede de Europa, no olvide que se juegan con dos ceros, lo que aumenta las posibilidades del Casino, juegue a este juego solo para divertirse, porque normalmente la banca siempre gana.

Keno es una especialidad local, se puede jugar en prácticamente cualquier parte del hotel, ya que los que admiten apuestas de Keno están por todas partes! Keno es una especie delotería, y las posibilidades de ganar son muy reducidas, muy divertido, pero no espere arruinar la banca.

Tenemos por supuesto las **máquinas tragaperras!** El hecho de que la mayoría de los ingresos de los casinos provengan de las máquinas tragaperras significa

algo, el problema es que es aditivo y la mayoría de la gente invierte lo que ha ganado por el hecho de ver cuánto aguanta, es cierto que se ve gente que gana, pero no mucha.

El hecho de que mientras esté jugando el casino te invita a las bebidas es una ventaja, sólo hay que pensar que te estás ahorrando unos siete dólares por cocktail! no está perdiendo del todo! La mayoría de los Casinos cuentan con Slots Clubs, si va a jugar mucho, hagase socio de uno, obtendrá una tarjeta que refleja las ganancias y tendrá descuentos incluso antes de jugar.



Si se toma el juego en serio, sus mejores apuestas son Blackjack y los Dados, ya que los casinos ofrecen tutorías para todos los niveles cada mañana, atiende a esas clases y sus posibilidades de ganar aumentarán y podrá volver a lo mejor a casa con algo de dinero, pero sólo a lo mejor!



Game - Juego	Casino advantage - Ventajas del Casino
Baccarat	1.17% on bank bets - 1.36% on player bets
Blackjack	0.5% to 5.9% for most games
Craps	1.4% to 17% depending on the bet
Keno	20 to 35%
Roulette	5.6% to 7.89% depending on the bet
Slots - Tragaperras	2% to 25% (average 4% to 15%)
Video Poker	1% to 12% (average 4% to 8%)
Wheel of Fortune	11% to 24%

Take in a Show

Las Vegas has bigger, flashier and more shows than anywhere else on earth, by a wide margin. Some are so spectacular and expensive to stage, that they could only happen here.

There are too many to list them all, so here are a few that we know to be good, unique or popular. Tickets can be purchased at the desk in your hotel, or online and for the miserly there are agencies that sell half-price tickets after midday for that evening's performance. However don't expect to find too many discounted tickets for top line shows, especially with over 150,000 visitors in town.



We love the Cirque de Soleil and with eight different shows in town there is a lot of choice. The longest running is *Mystère* at Treasure Island a combination of odd ball humour and incredible

acrobatic acts. "O" at Bellagio with lots of water (eau). *KÀ* at the MGM Grand combines martial arts, puppetry and pyrotechnics. *Zumanity* at New York, is sensual and erotic. *Love* at the Mirage includes lots of Beatles music and



video effects. *Criss Angel - Believe* is a haunting look inside the mind of the magician at the Luxor. *ONE* is a fusion of acrobatics, dance and visuals through the music and spirit of Michael Jackson and finally *Zarcana* at the Aria Hotel is an

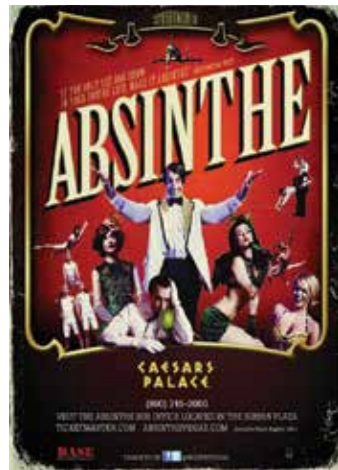

acrobatic rock experience blending circus arts with the surreal.

A relatively new show in town is *Absinthe* at Caesars Palace, imagine Cirque du Soleil combine with the *Rocky Horror Picture Show*. Skill, erotic innuendo and zaniness. *Carrot Top* is a red headed 'prop comedian' at the Luxor said to be fantastic, but the top show in town according to most audience surveys is the *Jersey Boys* at the Paris, definitely worth getting tickets for.

The *Blue Man group* with its three bald blue men has updated its long running show and definitely not for the up-tight! If you're shy don't sit at the front! The world famous *Penn & Teller* at the Rio is unlike any other magic production and speaks for itself.



Finally *Celine Dion* has a new show at the Colosseum in Caesars Palace is said to be fantastic, but it's not on every day, in *Conexpo* week it can be seen Tuesday, Wednesday, Friday and Saturday March 8th.

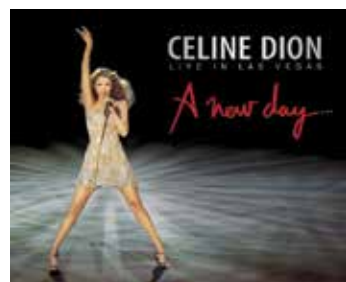

Disfrute de un Espectáculo

Las Vegas tiene los espectáculos más grandes y más llamativos que cualquier otro lugar en la tierra, por un amplio margen. Algunas son tan espectaculares y costosos que sólo podrían ocurrir aquí.



el Aria Hotel es una experiencia de rock acrobática que mezcla las artes circenses con lo surrealista.

Un espectáculo relativamente nuevo en la ciudad es *Absinthe*, en el Caesars Palace, imagine que Cirque du Soleil se combina con el *Rocky Horror Picture Show*. Habilidad, insinuaciones eróticas y extravagancia. *Carrot Top* es



Os explicamos algunos que sabemos que son buenos, únicos o populares. Las entradas pueden adquirirse en el hotel, o en línea y hay agencias que venden entradas a mitad de precio después del mediodía para esa noche. Dese prisa con las entradas, habrá más de 150.000 visitantes de la ciudad.

Nos encanta el Cirque de Soleil y con ocho espectáculos diferentes de la ciudad hay un montón de opciones. El de más larga duración es *Mystère* en Treasure Island una combinación de humor y actos acrobáticos increíbles. "O" en el Bellagio con mucha agua (EAU). *KÀ* en el MGM Grand combina artes marciales, marionetas y pirotecnia. *Zumanity* en Nueva York, es sensual y erótico. *Love* en el Mirage incluye un montón de música de los Beatles y de los efectos de vídeo. *Criss Angel - Believe* es una mirada inquietante



un pelirrojo comediante en el Luxor, se dice que es fantástico, pero el espectáculo mejor según la mayoría de los estudios de audiencia son los *Jersey Boys* en el Hotel París, definitivamente vale la pena conseguir entradas.

El grupo *Blue Man* con sus tres hombres azules calvos ha actualizado su show. El mundialmente famoso *Penn & Teller* en el Hotel Rio es diferente a cualquier otra producción de magia, Finalmente *Celine Dion* tiene un nuevo espectáculo en el Coliseo del Caesars Palace. La semana de *Conexpo* está los martes, miércoles, viernes y el sábado.



dentro de la mente del mago en el Luxor. *ONE* es una fusión de acrobacias, danza y visuales a través de

la música y el espíritu de Michael Jackson y finalmente *Zarcana* en



The ultimate aerial lift!

Taking a helicopter ride into the Grand Canyon is perhaps the ultimate lift. It has to be among the best ways to experience this magnificent landscape - one of the Seven Wonders of the World.

Our design team Chris, Brett and Danny took the helicopter ride to see the Grand Canyon for the very first time in February. First impressions are everything so when asked for theirs, the response was full on - 'breathtaking, fantastic, amazing to be there, stunned by the silence on the canyon floor and above all... nothing really to do but take it all in'. So if you are debating what to do with any spare time in Las Vegas, a helicopter ride sounds just the ticket.

The trips are generally well organised and very easy to book through a host of locally based Las Vegas companies who can be contacted either through your hotel concierge, the internet or by simply using the golden pages. As you might imagine, the cost of flights will vary according to the length of the trip and the amount of time you spend on the Canyon floor.

Sundance Helicopters for example runs four trips a day, two in the morning, one over lunch and one early evening. For \$299 (plus \$23 fuel surcharge) you can get a three and a half hour trip which starts with a stretch limo pick-up at your hotel, a brief safety video at the airport and then a fabulous ride over Lake Mead, the Hoover Dam and the Grand Canyon with 45 minutes on the Canyon floor and a champagne lunch (albeit it basic) thrown in! The return journey takes in the entire Strip passing over the Stratosphere Tower.

For an extra \$60 you can buy a DVD of your trip which is posted to your home address and souvenirs are available to buy from the airport shop.



Aterrizando en el Cañón (I-D) - Brett, Danny y Chris

Landing on the canyon floor (L-R) - Brett, Danny and Chris.

Some facts on the Grand Canyon. One of the Seven Wonders of the World it is:

- Over two billion years old
- A mile (1.6km) deep and 10 miles (16km) wide
- Habitation dates back 4,000 years
- Helicopter companies are required to pay \$1million a year to the Indian Reservation for the privilege of landing
- Information and bookings for all types of visits to the canyon starting at \$260 can be made through www.grandcanyonourcompany.com or call 1-800 2 CANYON

Other day trips and attractions:

- Hoover Dam to see both the dam and construction of a new bridge
- Mojave desert
- Atomic testing museum actually in Las Vegas
- Automobile collection at the Imperial Palace
- Liberace museum

Hecho por el hombre y muy impresionante! El viaje incluye volar sobre la presa Hoover



Man-made but impressive! The trip flies over the Hoover Dam.



La última vista aérea - El Gran Cañón y el Rio Colorado - 1400 millas de largo

The ultimate 'Aerial View' - The Grand Canyon and the great Colorado River - 1400 miles long.

Lo ultimo en elevacion!

Coger un helicóptero al Gran Cañón es quizás lo ultimo en elevación. Es una de las mejores experiencias de disfrutar de este magnifico paisaje - una de las siete maravillas del mundo!

Nuestro equipo de diseño, Chris, Brett y Danny han hecho la excursión en helicóptero por primera vez en febrero. La primera impresión es la que cuenta, por lo que les hemos pedido la suya, que estaba llena de "te quita el aliento, fantástico, increíble el estar allí, asombrados por el silencio que allí se respira y sobre todo...nda más que disfrutarlo". Por lo que si está pensando qué hacer cuando vaya a Las Vegas, sin duda, una vuelta en helicóptero es su plan. Los viajes están muy bien organizados y son fáciles de reservar a través de muchas empresas locales en Las Vegas con las que puede contactar bien a través de su hotel o utilizando las páginas amarillas. Como podrá imaginar, el coste de los vuelos variará dependiendo de lo que dure el viaje y el tiempo que se pase en el Cañón. Sundance Helicopters por ejemplo realiza cuatro viajes por día, dos por la mañana, uno a la hora de comer y uno pronto por la tarde. Por \$299 (más \$23 de recargo de combustible) tiene un viaje de tres horas y media que comienza con una limusina recogiendo en el hotel, un vídeo de seguridad y un fabuloso viaje por el Lago Mead, la presa Hoover y el Gran Cañón, con 45 minutos sobre el suelo del Cañón, con una comida frugal con champán! El viaje de vuelta le lleva por

encima de la calle principal pasando sobre la torre Stratosphere. Por \$60 más puede adquirir el DVD de su día de excursión.

Algunos datos sobre el Gran Cañón, una de las Siete Maravillas del Mundo:

- Tiene más de dos billones de años de antigüedad.
- Con una milla (1.6km) de profundidad y 10 millas (16km) de ancho.
- Habitado desde hace 4,000 años
- Las empresas de helicópteros tienen que pagar \$1millón por año a la reserva india por el privilegio de aterrizar.
- Información y reservas o visitas al Cañón las puede hacer visitando www.xanterra.com o llamando al 888-297-2757

Otras excusiones de un día y atracciones:

- Presa Hoover para ver la presa y la construcción de un nuevo puente.
- Desierto del Mojave
- Museo Atómico, en Las Vegas
- Colección de Automóviles en el Imperial Palace
- Museo de la Liberación

Flying over Lake Mead. Each passenger wears headphones to listen to a commentary and ask the pilot questions.



Volando sobre el Lago Mead. Cada pasajero lleva cascos para escuchar los comentarios y hacer preguntas al piloto

Time for Golf?

The Golf enthusiasts among you will not need any encouragement with great weather and some superb courses most of which are open to the public. Our Golf expert has recommended the following ones first hand.

Las Vegas Paiute - Owned and operated by the Paiute native Americans. Three Great courses with open fairways, lush conditions, and a beautiful views of the desert mountains. Outside the city it is worth the drive.

Tel: 658-1400 or 888-921-2833

TPC Canyons - A beautiful desert course with challenging elevation changes. Home of the Las Vegas Invitational - a PGA tour stop and the place where Tiger Woods won his first professional PGA tournament.

Tel: 256-2000.
Bears Best - A recreated collection of the best holes of Jack Nicklaus courses from around the world. A unique experience with excellent service. Tel: 385-8500

Desert Pines - Only 15 minutes from the Strip we are told that it is a fun course requiring precise irons. With over 4,000 pine trees you can imagine why!

Tel: 450-8000 or 888-397-2499

Badlands - Designed by Johnny Miller and Chi Chi Rodriguez as three nine hole courses, our expert says it is a 'neat course tucked between casinos off the strip. A few tricky holes with water and desert hazards'.

Tel: 382-4653 or 800-468-7918.

Your concierge may recommend **Stallion Mountain** - thanks to its friendly arrangements with them. We hear that it is overpriced, overplayed and poorly maintained. With three courses it does have a good layout.

Other courses that we hear are good:

Reflection Bay - Said to be one of the best in town. A par 72 course on the shore of a man-made lake, designed by Jack Nicklaus
Tel:740-4653

Bali Hai - Located near the south end of the strip, with plenty of water features... watch out for palms and tropical plants.

Tel: 450-8000 or 888-397-2499.

Las Vegas National - A par 71 course which has hosted LPGA and PGA tour events. With a well lit driving range for those of you who are tied to the stand all day. Tel:796-0013

Revere at Anthem - The course winds through three desert canyons with natural changes of elevation and fantastic views of the Las Vegas Skyline. Tel:259-4653

For the frugal

Call **Stand by Golf** on 866-711-2665

to buy unsold tee-off times at discounts or between 30 and 50% or go online www.standbygolf.com
Las Vegas Golf Club - the first in town built in 1939 - is a bargain at \$49 after midday Tel: 646-3003

Black Mountain - 20 minutes out of town - \$75 a round it is a tough course and one of the few that will allow you to walk rather than use a cart.

And finally... for the few:

Shadow Creek apparently the most expensive course in the USA, and reserved for well heeled guests of MGM group hotels - Bellagio, Mirage, Treasure Island, New York, MGM, Luxor, Excalibur and Mandalay Bay, expect to pay \$500 for a round
Tel: 1.866.260-0069

Cascata apparently the most expensive course construction ever, fees start at \$240 during the week.
Tel: 294-2005



Tiempo para jugar al Golf?

Estoy segura que aquellos entusiastas del golf no necesitarán mucho esfuerzo en jugar, con buen tiempo y algunos super campos muchos de los cuáles están abiertos la mayoría al público. Nuestro experto en golf ha hecho un estudio de algunos campos, qué sacrificio! Y recomienda los siguientes. Las Vegas Paiute - Operado y perteneciente a los nativos americanos Paiute. Tres grandes campos. Con calles abiertas, condiciones suntuosas y preciosas vistas de las montañas del desierto. Fuera de la ciudad es mejor conducir. Tel: 658-1400 or 888-921-2833

TPC Canyons - Un campo en el desierto muy bonito con cambios y elevaciones. Hogar de Las Vegas

Invitational - una parada del tour del PGA y el lugar donde Tigre Woods ganó su primer torneo PGA profesional. Tel: 256-2000.

Bears Best - Una colección de los mejores hoyos de los campos de Jack Nicklaus de todo el mundo. Una experiencia única con excelente servicio. Tel: 385-8500

Desert Pines - A sólo 15 minutos de la calle principal de Las Vegas nos han dicho que es un campo "divertido" que requiere hierros precisos. Con más de 4000 pinos ya se puede imaginar por qué!
Tel: 450-8000 or 888-397-2499

Badlands - Diseñado por Johnny Miller y Chi Chi Rodríguez como tres campos de nueve hoyos, nuestro experto asegura que es un campo

bien cuidado entre casinos. Algunos hoyos engañosos con agua y obstáculos del desierto.

Tel: 382-4653 or 800-468-7918.

Su conserje quizás le recomiende

Stallion Mountain - gracias a sus sus convenios con ellos, pero hemos oído que esta sobre precio, muy concurrido y mal mantenido. Con campos de árboles tiene un buen trazado.

Otros campos que hemos oído que son buenos:

Reflection Bay: dice ser uno de los mejores en la ciudad, un campo de par 72, con un lago diseñado por Jack Nicklaus. Tel:740-4653

Bali Hai: Localizado en la parte sur de la calle principal, con mucho agua... cuidado con las palmeras y plantas tropicales. Tel: 450-8000 or 888-397-2499.

Las Vegas National Un campo de par 72 que ha acogido campeonatos de LPGA y PGA, con luz, muy bueno para aquellos que tienen que estar todo el día en el stand. Tel:796-0013

Revere at Anthem El campo se extiende a través de tres cañones del desierto con cambios naturales de nivel y una vista fantástica del Skyline de Las Vegas. Tel:259-4653

Para frugal

Llama a **Stand by Golf** al 866-711-2665 para encargar las salidas y descuentos entre 30 y 50% o visite www.standbygolf.com

Las Vegas Golf Club, el primero en la ciudad construido en 1939 es un chollo a \$49 después del mediodía. Tel:646-3003

Black Mountain - A 20 minutos de la ciudad, \$75 aunque es un campo difícil y uno de los pocos donde le dejarán caminar en vez de ir en carrito.

Y finalmente...para unos pocos: Shadow Creek aparentemente uno de los campos más caros de EE.UU., y reservado para invitados importantes del grupo de hoteles MGM - Bellagio, Mirage, Treasure Island, New York, MGM, Luxor, Excalibur y Mandalay Bay.

Cascata aparentemente el campo más caro en su construcción, con precios de \$240, pero es una experiencia única. Tel:294-2005.



Mini & Mobile Cranes Körner



used mobile cranes for sale

- 20 t COLES 920 HM (18/20), year 1983**
13,0 m boom, 1 winch, 4x2x2 drive, 10 t pick+carry
- 23 t TADANO TR 230 E, year 1987**
25 boom + 7,0 m jib, 2. winch, 4x4x4, Mitsubishi engine
- 25 t DEMAG AC 25 City, year 2000**
25 m boom +1,2 m runner, 4x4x4, Perkins engine
- 35 t LIEBHERR LTM 1030-2.1, year 2010**
30 m boom + 15,0 m jib, 4x4x4, LIEBHERR engine
- 65 t TADANO FAUN ATF 65G-4, year 2008**
44 m boom + 16 m jib, 8x6x8, 2x MB engines, 15 t cw
- 70 t TADANO FAUN ATF 70-4, year 1998**
40,5 m boom + 16 m jib, 8x8x8, 2x MB engines
- 100 t GROVE GMK 5100, year 2000**
51 m boom +34 m jib, 10x8x10, 2. winch, 31 t cw
- 350 t TEREX AC 350/6 SL, year 2010**
64 m boom, 72 m luffing fly jib, 116,7 t cw, Superlift

Mini & Mobile Cranes Körner GmbH
Alte Kaserne 23, 47249 Duisburg, Germany
www.unic-mobilecranes.de

Tel: 0049 203-713 68 760
Fax: 0049 203-713 68 7619
info@unic-mobilecranes.de

Did you know

that printed copies of every issue of **Cranes & Access** are mailed to named readers in the following countries:

Albania • Australia • Austria • Bahrain • Belarus • Belgium
Bermuda • Brazil • Bulgaria • Cameroon • Canada • Chile
China • Colombia • Costa Rica • Croatia • Cyprus
Czech republic • Denmark • Egypt • Estonia • Finland • France
Georgia • Germany • Ghana • Gibraltar • Greece • Hong Kong
Iceland • India • Indonesia • Iran • Ireland • Israel • Italy • Japan
Jordan • Kenya • Korea • Kuwait • Latvia • Lebanon • Lithuania
Luxembourg • Macedonija • Malaysia • Malta • Mauritius
Mexico • Montenegro • Netherlands • New Zealand
Nigeria • Norway • Oman • Pakistan • Panama • Peru
Philippines • Poland • Portugal • Qatar • Romania • Russia
Saudi • Arabia • Serbia • Singapore • South Africa
South Korea • Spain • Sweden • Switzerland • Thailand
Tunisia • Turkey • Ukraine • United Arab Emirates
United Kingdom • United States
of America • Venezuela
West Indies • Yugoslavia

**cranes
& access**

M. Stemick GmbH
Kran- u. Baumaschinenhandel

CRANES FOR SALE

ALL TERRAIN-CRANES

Make / Type	y. o. m.	Drive	Boom / Fly Jib
20 t Gottwald AMK 31-21	1984	4x4x4	20,50m
25 t Demag AC 75	1998	4x4x4	25,00m + 13,00m
30 t PPM ATT 335	1997	4x4x4	27,40m + 15,00m
35 t Terex AC 35	2006	4x4x4	30,40m + 15,00m
35 t Liebherr LTM 10502	2003	4x4x4	30,00m + 15,00m
40 t Demag AC 40-1 City	2001	6x4x6	31,20m + 13,00m
40 t Liebherr LTM 1040-1	1999	6x4x6	30,00m + 14,50m
55 t Liebherr LTC 1055-3.1	2005	6x6x6	36,00m + 7,80m
55 t Liebherr LTC 1055-3.1	2005	6x6x6	36,00m + 7,80m
55 t Knupp KMK 4055	1989	8x6x8	35,10m + 16,00m
55 t Grove GMK 3055	2006	6x6x6	43,00m + 15,00m + 2,00m
70 t Knupp KMK 4070	1995	8x6x8	38,10m + 16,00m
70 t Faun ATF 70-4	1999	8x8x8	40,50m + 16,00m
80 t Faun ATF 80-4	2005	8x6x8	48,50m + 16,00m
100 t Grove GMK 4100 L	2008	8x8x8	60,00m + 22,00m
100 t Grove GMK 5100	2002	10x8x10	51,00m + 18,00m
110 t Tadano Faun ATF 110G-5	2008	10x8x8	52,00m + 16,20m
120 t Liebherr LTM 11201	2000	10x8x10	56,00m + 28,00m + 3,00m
130 t Liebherr LTM 1130-5.1	2007	10x8x10	60,00m + 19,00m
200 t Grove GMK 5200	2002	10x8x10	60,00m + 36,00m
300 t Liebherr LTM 13001	2000	12x8x12	60,00m + 49,00m
400 t Liebherr LTM 1400-7.1	2004	14x8x14	60,00m + 56,00m + 84,00m

RT-TELESCOPIC-MOBILE-CRANES

Make / Type	y. o. m.	Drive	Boom / Fly Jib
55 t Grove RT 760 E	2005	4x4x4	33,50m + 17,10m

LATTICE-BOOM-TRUCK-CRANES

Make / Type	y. o. m.	Drive	Boom / Fly Jib
115 t Link-Belt HC 238	1982	10x6x6	48,00m/18,00m
170 t Demag TC 650	1981	10x4x6	72,00m/60,00m

YARD-CRANES

Make / Type	y. o. m.	Drive	Boom / Fly Jib
14 t Demag V 73	1988	4x2x2	13,10m
12 t Liebherr LI 1012	1990	4x2x2	12,00m

Tel.: +49-2364 - 108203

Fax: +49-2364 - 15546

Mobile: +49-172-2332923

e-Mail: info@stemick-krane.de

Internet: <http://www.stemick-krane.de>

M. Stemick GmbH
Kran- u. Baumaschinenhandel
Import • Export
D-45721 Hattem / Germany



Import • Export

WHAT DOES IT COST?

LECTURA It's good to know YOBUM Purchase

EVALUATE

Aerial work platform **WITH LECTURA**

PRINT AND ONLINE

valuation.lectura.de

VISIT US AT
CONEXPO
Booth: 60110



LECTURA
It's good to know



VISIT US AT BOOTH
1986
GOLD Lot

**Haydock
Park**

**May 14th &
15th 2014**

Don't miss the UK's number one lifting event

the only specialist equipment event for the UK and Ireland

If you buy, use or have a professional interest in Access Equipment, Working at Height, Mobile Cranes, Tower Cranes and Loader Cranes, not to mention Telehandlers then register now for the UK and Ireland's event for lifting professionals – Vertikal Days.

See the latest equipment and services, meet the experts and enjoy a day of networking, deal-making and socialising.

email the Vertikal Team at
info@vertikaldays.net
UK Office +44 (0) 8448 155900

www.vertikaldays.net

**Vertikal
days**



Toll Free: **888-959-6287**



CRANE MATS



COMPOSITE MATS



76 PRODUCTION AND



EASTERN OFFICE 888-963-9208 MIDWEST OFFICE 503-970-3575 SOUTHERN OFFICE 601-255-1155

Toll Free: 888-959-6287 (*MATS) 24 Hr. Mobile: 503-550-8761



TIMBER MATS



BRIDGE MATS



**Rental,
purchase &
buy back
options.
New &
used mats.**

STOCKING LOCATIONS 



NORTHERN OFFICE 503-550-8761

CANADA OFFICE 503-970-3575

WEST OFFICE 888-959-6287

Fax: 601-255-1156 Email: Spartan@SpartanMat.com

GOING UP IN THE WORLD

A history of Simon Engineering and the development of the powered access industry by Denis Ashworth

Ordering Information

Forename: _____ Surname: _____
 Address: _____
 Post Code: _____
 Email: _____ Telephone: _____
 I enclose a cheque for £18 (£14.50 + £3.50p&p) made payable to The Vertical Press Ltd
 Please debit my card:
 Card No: _____ Issue No: _____
 Expiry Date: _____ 3 Digit Security Code: _____
 Signature: _____ Date: _____

Please send completed order form to: The Vertical Press, Box 6998 Brackley, NN13 5WY, UK. Alternatively, fax it through on +44(0)1295 768273 or scan & email info@vertical.net



MOVICARGA

MOVIMIENTO DE CARGAS

Revista de elevación líder de habla hispana

www.movicarga.com

macarenagarcia@gilusan.com

More than 16,500 readers in Latinamerica



Ihr Partner für gebrauchte Mobilkrane
Your partner for used mobile cranes

Tel.: +49 (0)2853 60414 0 Fax: +49 (0)2853 60414 44
 Im Heetwinkel 38, D-46514 Schermbeck

Email: mail@imc-cranes.com web: www.imc-cranes.com

100 t

80 t

50 t

Weitere Krane / Im Zulauf



Demag AC 100/4L, 2010



Tadano Faun ATF 80-4, 2003



Demag AC 50-1, 2007

- | | |
|------------------------------|-----------------------------|
| Liebherr LTM 1030-2.1, 2007 | Terex TC 60 L, 2007 |
| Demag AC 40, 1999 | Terex Demag AC 60, 2002 |
| Demag AC 40-2, 2008 | Tadano Faun ATF 70-4, 2001 |
| Liebherr LTF 1045, 4.1, 2009 | Demag AC 100-5, 2009 |
| Demag 3160 Challenger 2012 | Liebherr LTM 1150-6.1, 2009 |

www.imc-cranes.com

Preise auf Anfrage/ Änderungen und Zwischenverkauf vorbehalten/ Farbabweichungen möglich/ Prices on request/ Subject to changes and prior sale/ Colour variation possible



V12801 - Skyjack SJ3219 - 2004
Electric - 7.80 Mtr. - 139 Hrs.
€ 3.500



V14889 - Snorkel S2033E - 2005
Electric - 8.10 Mtr. - 223 Hrs.
€ 3.000



V14214 - Haulotte Compact 8 - 2008
Electric - 8.20 Mtr. - 304 Hrs.
€ 4.750



V15115 - JLG 2646ES - 2006
Electric - 9.80 Mtr. - 389 Hrs.
€ 6.500 - NEW TYRES



V15281 - Genie GS2646 - 1999
Electric - 9.92 Mtr. - 1119 Hrs.
€ 3.250



V15287 - JLG 33RTS - 1999
Diesel 4x4 - 12.06 Mtr. - 4442 Hrs.
€ 4.250



V15368 - Haulotte C12DX - 2005
Diesel 4x4 - 12.15 Mtr. - 2214 Hrs.
€ 8.500



V13459 - Skyjack SJ8841 - 2007
Diesel 4x4 - 14.50 Mtr. - 499 Hrs.
€ 12.500



V13832 - JLG 500RTS - 1997
Diesel 4x2 - 17.24 Mtr. - 4053 Hrs.
€ 7.500



V14313 - Skyjack SJ9250 - 2007
Diesel 4x4 - 17.20 Mtr. - 1237 Hrs.
€ 15.500



V15096 - JLG Toucan 861 - 2008
Electric - 8.72 Mtr. - / Hrs.
€ 9.500



V15380 - Haulotte STAR 10 - 2007
Electric - 10 Mtr. - 467 Hrs.
€ 10.500



V15222 - JLG E300AJ - 2001
Electric - 11.14 Mtr. - 983 Hrs.
€ 9.000



V11316 - Genie Z30/20N - 2007
Electric - 11.14 Mtr. - 397 Hrs.
€ 16.000 - NEW WHEELS & BATTERIES



V15098 - Manitou 120AETJ 3D - 2003
Electric - 11.95 Mtr. - 943 Hrs.
€ 10.500



V15047 - Genie Z34/22RT - 2001
Diesel 4x4 - 12.62 Mtr. - 3727 Hrs.
€ 6.750



V15031 - Genie Z45/25JRT - 2001
Diesel 4x4 - 16 Mtr. - 3970 Hrs.
€ 11.500



V14812 - Haulotte HA16SPX - 2007
Diesel 4x4 - 16 Mtr. - 2388 Hrs.
€ 16.500



V14392 - JLG 510AJ - 2006
Diesel 4x4 - 17.61 Mtr. - 2317 Hrs.
€ 21.500



V15296 - Genie Z80/60RT - 2005
Diesel 4x4 - 26.40 Mtr. - 2284 Hrs.
€ 40.000



V12564 - Haulotte H14TX - 2002
Diesel 4x4 - 14.07 Mtr. - 2961 Hrs.
€ 6.950



V14617 - JLG 860SJ - 2007
Diesel 4x4 - 28.21 Mtr. - 3224 Hrs.
€ 51.000



V14577 - Genie S125 - 2003
Diesel 4x4x4 - 40.15 Mtr. - 4137 Hrs.
€ 52.500



V14874 - Denka Lift DL21 - 2006
Electric - 21 Mtr. - 1404 Hrs.
€ 17.500



V14827 - Denka Lift DL25 - 2006
Electric - 25 Mtr. - 694 Hrs.
€ 24.500



The world authority
in powered access

Visit the IPAF Lift
Safety Zone at
ConExpo, Gold
Lot #1817



If you use one of these,



you need one of these.

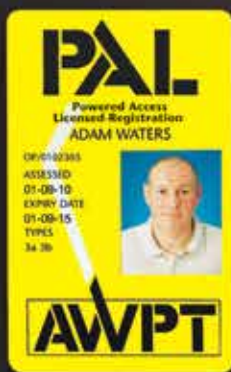

Our approved training centers train more than 100,000 operators every year in the safe and effective use of powered access platforms.

The AWPT PAL Card is recognized worldwide across industries as proof that your operators have been trained to the highest safety standards and meet all legal requirements.

Find an AWPT approved training center at www.AWPT.org

AWPT operator training is based on the IPAF program which is certified by TÜV as conforming to the international standard ISO 18878. AWPT operator training meets or exceeds OSHA requirements and ANSI standards.

